

Installation Manual



MADRONA

Direct Vent Zero Clearance
Freestanding Gas Fireplace
natural gas MF28VN
propane gas MF28VP

Installer: Place model/serial number here.

Installer: Leave this manual with the appliance.
Consumer: Retain this manual for future reference.

⚠ WARNING:
FIRE OR EXPLOSION HAZARD

Failure to follow safety warnings exactly could result in serious injury, death, or property damage.

Do not store or use gasoline or other flammable vapors and liquids in the vicinity of this or any other appliance.

WHAT TO DO IF YOU SMELL GAS

- Do not try to light any appliance.

- Do not touch any electrical switch; do not use any phone in your building.
- Leave the building immediately.
- Immediately call your gas supplier from a neighbor's phone. Follow the gas supplier's instructions.
- If you cannot reach your gas supplier, call the fire department.

Installation and service must be performed by a qualified installer, service agency or the gas supplier.

⚠ DANGER



Hot glass will cause burns.

Do not touch glass until cooled.

Never allow children to touch glass.

A barrier designed to reduce the risk of burns from the hot viewing glass is provided with this appliance and must be installed for the protection of children and other at-risk individuals.

This appliance may be installed in an after-market permanently located, manufactured (mobile) home where not prohibited by local codes. This appliance is only for use with the type of gas indicated on the rating plate. This appliance is not convertible for use with other gases, unless a certified kit is used.

INSTALLER: Leave this manual with the appliance.
CONSUMER: Retain this manual for future reference.

Massachusetts:

The piping and final gas connection must be performed by a licensed plumber or gas fitter in the State of Massachusetts. Also, see Carbon Monoxide Detector requirements on page 39 in this manual.

⚠ WARNING

This product can expose you to chemicals including Benzene, which is known to the State of California to cause cancer and birth defects or other reproductive harm. For more information go to www.P65Warnings.ca.gov.

Note: Natural gas, in its original state, contains Benzene.

This manual contains instructions to install the **ENGINE ONLY**. A stove casing is **REQUIRED** to complete this installation. A barrier screen is provided with the casing. **Refer to the manual supplied with the casing for installation.**

This appliance is a domestic room-heating appliance. It must not be used for any other purposes such as drying clothes, etc.

This appliance is suitable for installation in a bedroom or bed sitting room.

Ce guide est disponible en français sur demande.



We recommend a US Certified National Fireplace Institute (NFI) specialist install our gas hearth products.



The information contained in this manual is believed to be correct at the time of printing. Miles Industries Ltd. reserves the right to change or modify any information or specifications without notice. Miles Industries Ltd. grants no warranty, implied or stated, for the installation or maintenance of your heater, and assumes no responsibility for any consequential damage(s).

© Copyright Miles Industries Ltd., 2024. All rights reserved.
Designed and manufactured for Miles Industries Ltd.

Welcome to Valor®

This appliance has been professionally installed by:

Dealer Name: _____

Phone: _____

Please read this manual BEFORE installing and operating this appliance.

Stove Safety	4
Specifications	6
Kits & Accessories	7
Dimensions & Clearances	8
Venting	10
Overview	10
Co-Axial	11
Typical Co-Axial Venting Components.....	11
Venting Chart.....	12
Venting Diagram.....	13
Restrictors.....	14
Horizontal Vent Termination Location.....	15
Vertical Vent Termination.....	16
Co-Axial Flex Conversion	17
Applications.....	17
Existing Fireplace Preparation.....	17
Partial Installation Into an Existing Chimney or Into an Adjacent Chimney with 590CFA.....	18
Preparation	20
Before Installing	20
Installation	21
Window & Optional Fan	21
Vent Outlet	22
Gas Supply	23
Fuel Beds	24
Traditional Log Set MF28VLSK.....	24
Driftwood Kit MF28VDWK.....	26
Birch Logs MF28VBLK.....	29
Refit & Check Window	31
Battery Holder	32
Remote Control Pairing	33
Operation Check & Burner Aeration	34
Barrier Screen & Accessories	35
Wiring Diagram	36
Approved Venting Components	37
Commonwealth of Massachusetts	39
Appendix A – Lighting Instructions Plate	40
Appendix B – Remote Control Operation	41
Appendix C – Spare Parts	45

Stove Safety

This manual contains very important information about the safe installation and operation of the stove. Read and understand all instructions carefully before installing and operating the stove. Failure to follow these instructions may result in possible fire hazard and will void the warranty.

Replacement manuals are available by contacting the Valor Customer Service at 1-800-468-2567, or by visiting valorfireplaces.com.

WARNING: Extremely Hot!

Heat and flammability

- Some parts of the stove are extremely hot, particularly the glass windows. Use the barrier screens provided or a gate to reduce the risk of severe burns.
- The glass windows can exceed 500°F at full capacity.
- Always keep the appliance clear and free from combustible materials, gasoline, and other flammable vapors and liquids.
- Be aware of hot surfaces! The top of the stove will get very hot when the stove heats. Do not touch or put anything on it!
- Be aware of hot surfaces in front of the stove. Although safe, a hearth directly in front of the stove can get very hot when the stove heats. Do not place anything on it!
- Some materials or items, although safe, may discolor, shrink, warp, crack, peel, and so on because of the heat produced by the stove. Avoid placing candles, paintings, photos and other combustible objects sensitive to heat or furniture within 36 inches (0.9 m) around the stove.
- Solid wood flooring in front of the stove (if allowed) may shrink during the heating season due to heat.
- Due to its high temperatures, the appliance should be located out of traffic areas and away from furniture and draperies.
- Clothing or flammable material should not be placed on or near the appliance.

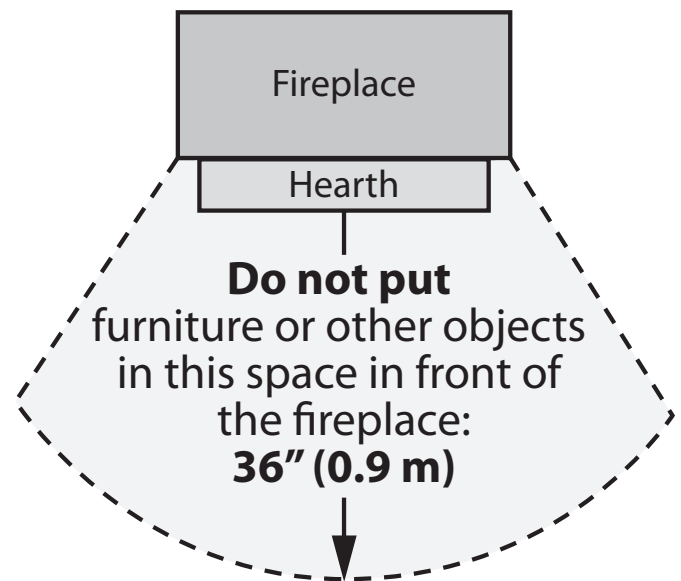

Barrier Screen and Safety

- A barrier designed to reduce the risk of burns from the hot viewing glass is provided with this appliance and shall be installed for the protection of children and other at-risk individuals.
- Children and adults should be alerted to the hazards of high surface temperature and should stay away to avoid burns or clothing ignition.
- Young children should be carefully supervised when they are in the same room as the appliance. Toddlers, young children, and others may be susceptible to accidental contact burns. A physical barrier is recommended if there are at-risk individuals in the house. To restrict access to a fireplace or stove, install an adjustable safety gate to keep toddlers, young children, and other at-risk individuals out of the room and away from hot surfaces.
- Any safety screen, guard, or barrier removed for servicing an appliance must be replaced prior to operating the appliance.

Stove Safety

Glass windows



WARNING

Do not operate this appliance with the glass front removed, cracked, or broken.

Do not strike or slam the glass front.

Replacement of the glass front should be performed by a licensed or qualified service person.

- The glass front assemblies must be in place and sealed before the unit can be placed into safe operation.
- The glass front assemblies must only be replaced as complete units, as supplied by the fireplace manufacturer. No substitute material may be used.
- Do not use abrasive cleaners on the glass front assemblies. Do not attempt to clean the glass when it is hot.

Venting

- This unit must be used with a vent system as described in this manual. No other vent system or components may be used.
- Never obstruct the flow of combustion and ventilation air. Keep the front of the appliance clear of all obstacles and materials for servicing and proper operation.
- This gas stove and vent assembly must be vented directly to the outside and must never be attached to a chimney serving a separate solid fuel burning appliance. Each gas appliance must use a separate vent system. Common vent systems are prohibited.

Intended use

- This appliance is designed and approved as a supplemental heater and provides the potential for most energy conservation when used while attended. The use of an alternate primary heat source is advisable.
- This unit is not for use with solid fuel.
- Do not use this heater as a temporary source of heat during construction.

Installation and Servicing

- Installation and repair should be done by a qualified service person. The appliance should be inspected before use and at least annually by a professional service person. More frequent cleaning might be required due to excessive lint from carpeting, bedding material, et cetera. It is imperative that control compartments, burners, and circulating air passageways of the appliance be kept clean.
- Do not use this appliance if any part has been under water. Immediately call a qualified service technician to inspect the appliance and to replace any part of the control system and any gas control that has been under water.

Specifications

Approval & Codes

This appliance is certified to ANSI Z21.88/CSA 2.33 American National Standard / CSA Standard for Vented Gas Fireplace Heaters for use in Canada and USA, and to CGA 2.17-M91 High Altitude Standard in Canada. This appliance is for direct vent installations.

This appliance complies with CSA P.4.1-15 Testing method for measuring annual fireplace efficiencies.

The installation must conform to local codes or, in the absence of local codes, with the National Fuel Gas Code, ANSI Z223.1/NFPA 54 or the Natural Gas and Propane Installation Code CAN/CGA-B149.1. Only qualified licensed or trained personnel should install this appliance.

This appliance must be electrically grounded in accordance with local codes, or, in the absence of local codes, with the National Electrical Code, ANSI/NFPA 70 or the Canadian Electrical Code, CSA C22.1.

Ratings

Model	MF28VN	MF28VP
Gas	Natural	Propane
Altitude (Ft.)*	0-4,500 feet*	
Input Maximum (Btu/h)	26,000	24,000
Input Minimum (Btu/h)	15,500	15,200
Manifold Pressure (in w.c.)	3.6"	9.3"
Minimum Supply Pressure (in w.c.)	5.0"	11.0"
Maximum Supply Pressure (in w.c.)	11.0"	14.0"
Main Burner Injector Marking	82-750	92-260
Pilot Injector Marking	BL22N	BL14P
Min. Rate By-Pass Screw	185	135

*High Altitude Installations

Input ratings are shown in BTU per hour and are certified without deration for elevations up to 4,500 feet (1,370 m) above sea level.

For elevations above 4,500 feet (1,370 m) in USA, installations must be in accordance with the current ANSI Z223.1 and/or local codes having jurisdiction. Heating value of gas in some areas is reduced to compensate for elevation—consult your local gas utility to confirm.

For installations at elevations above 4,500 feet (1,370 m) in Canada, please consult provincial and/or local authorities having jurisdiction.

Supply Gas

Heater engine MF28VN is used with natural gas.

Heater engine MF28VP is used with propane gas.

The supply pressure must be between the limits shown in the Ratings table.

The supply connection is 3/8" NPT female.

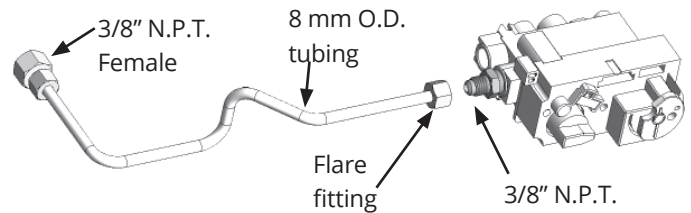

Gas Conversion

The MF28 stove is offered with natural gas or propane gas. It can be converted from one gas to the other. See installation manual supplied with the gas conversion kit for more information.

Combustible Materials

Combustible materials are defined as materials made of or surfaced with wood, compressed paper, plant fibers, or other materials that are capable of being ignited and burned.

Such material shall be considered combustible even though flame-proofed, fire-retardant treated, or plastered.

Electrical

The Madrona does not require an electrical power source unless fitted with the optional circulating fan 555CFK—see page 21.

Hearth Requirements

This appliance is approved for installation directly on combustible wood flooring. If installed directly on carpeting, vinyl or soft combustible floor other than wood, it must be installed on a metal or wood panel covering a minimum surface of 15 inches deep by 28 inches width.

Specifications

Madrona Stove

There are two types of stove casing for the Madrona MF28V engine, a traditional style available in two colors and a contemporary style. The stove casings are sold separately.

MFCS01—Traditional Stove Black, arched or square fronted

MFCS02—Traditional Stove Majolica Brown, arched or square fronted

MFCS05—Modern Stove offered with Almond White, Black or Pewter accents

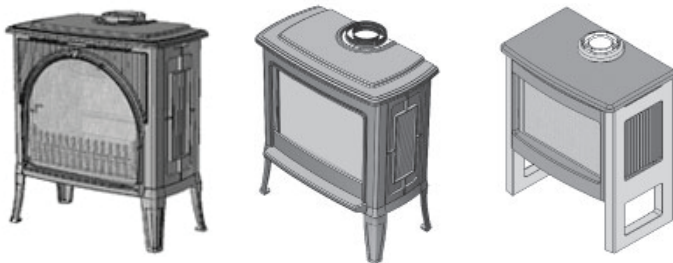

Traditional Stove—arched or square fronted MFCS01 or MFCS02 Modern Stove MFCS05

WARNING

HOT HEARTH/FLOOR! The hearth or floor in front of the stove may become very hot when it heats. Do not use the hearth as a seat or shelf. Solid wood flooring in front of the stove (if allowed) may shrink during the heating season due to heat.

WARNING

Some materials or items, although safe, may discolor, shrink, warp, crack, peel, and so on because of the heat produced by the stove. Avoid placing candles, paintings, photos, and other items sensitive to heat around the fireplace.

Kits & Accessories

Required Kits

Fuel Beds (choose one)		
MF28VLSK	Traditional Logs	
MF28VDWK	Driftwood Logs Kit	
MF28VBLK	Birch Logs Kit	
Stove Casing (choose one)		Barrier Screen
MFCS01V	Traditional Stove Black	
-2	Arched Front	4011870
-3	Square Front	4011104
MFCS02	Traditional Stove Majolica Brown	
-2	Arched Front	4003311
-3	Square Front	4004796
MFCS05	Modern Stove	
-AW	Almond White	4007217
-BK	Black	
-PW	Pewter	

Optional Accessories

Gas Conversion Kits	
MA28VNK	Conversion to natural gas
MA28VPK	Conversion to propane gas
Other Accessories	
555CFK	Circulating Fan Kit
1265WSK	Wall Switch Kit
RBWSK	Remote Battery & Wall Switch Kit
Hearth Gate	Hearth gates such as Cardinal's VersaGates are available at retail stores carrying safety products for children.

Information accurate at the time of printing and subject to change without notice.

Dimensions & Clearances

Traditional Cast Stove MFCS01 (black) or Traditional Cast Stove MFCS02 (Majolica brown)—
arched or square fronted

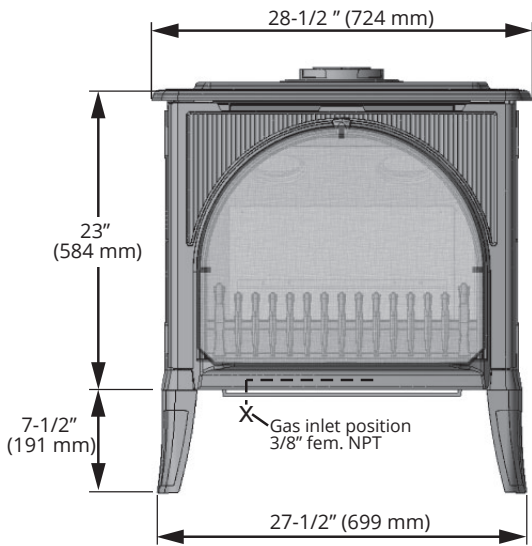
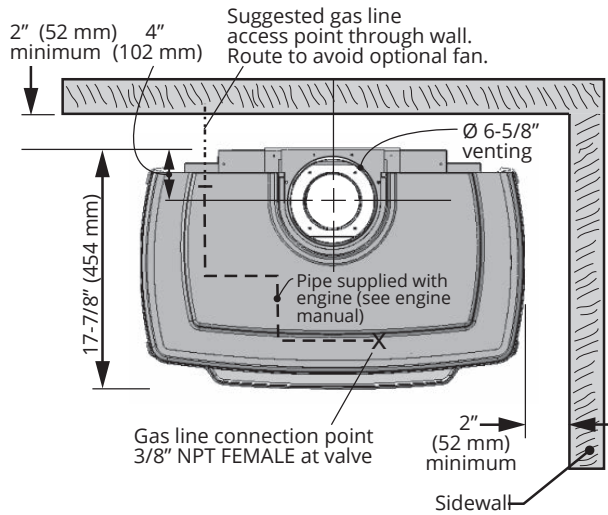

Mantel / shelf clearances

Mantel Depth 'A'	0-1" (0-26 mm)	2-5" (51-127 mm)	6-18" (152-457 mm)	19-24" (483-610 mm)
Mantel Height 'B'	34" (864 mm)	36" (914 mm)	38" (965 mm)	42" (1067 mm)

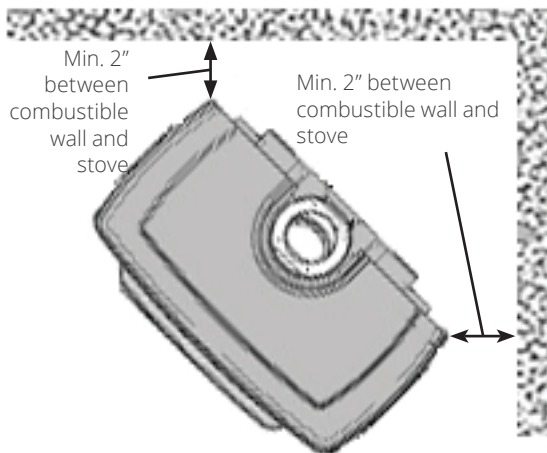
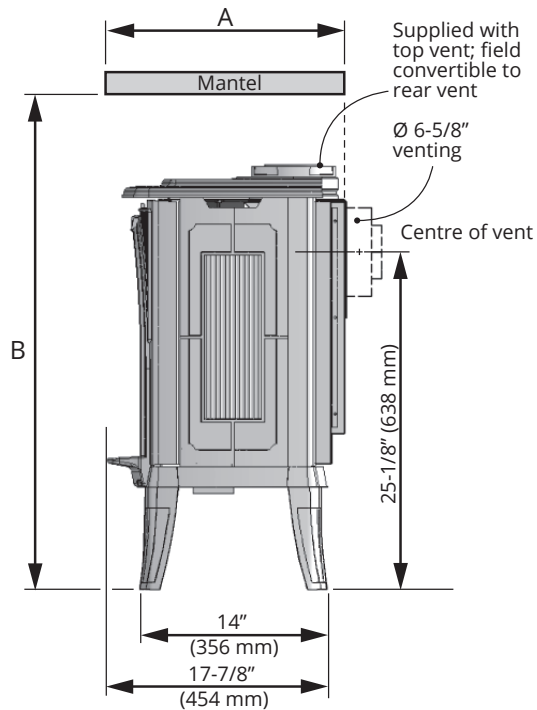

Corner clearances

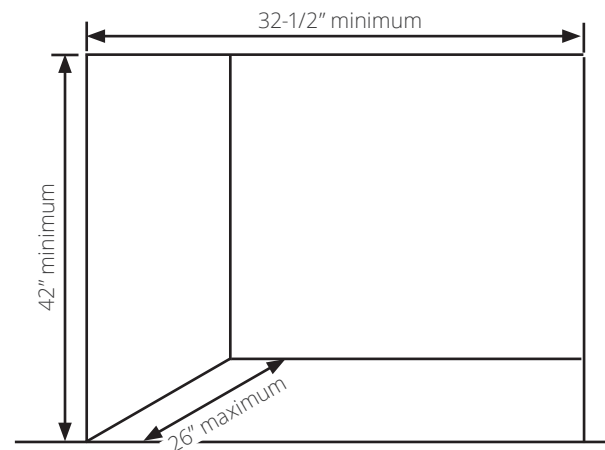

Alcove clearances

Dimensions & Clearances

Modern Stove MFCS05

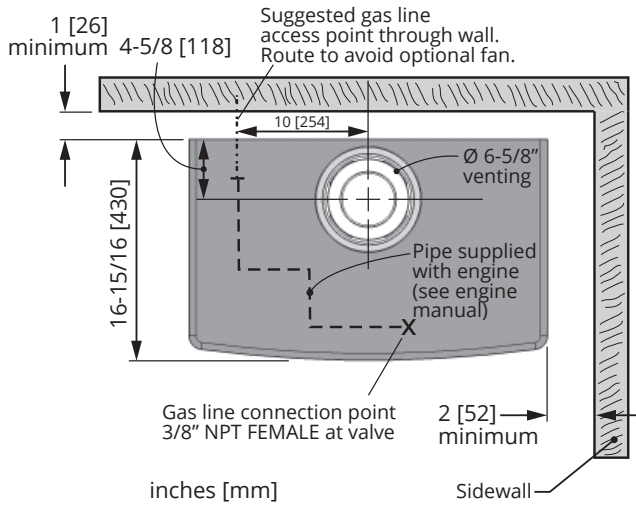

Mantel / shelf clearances

Mantel Depth 'A'	0-1" (0-26 mm)	2-5" (51-127 mm)	6-18" (152-457 mm)	19-24" (483-610 mm)
Mantel Height 'B'	34" (864 mm)	36" (914 mm)	38" (965 mm)	42" (1067 mm)

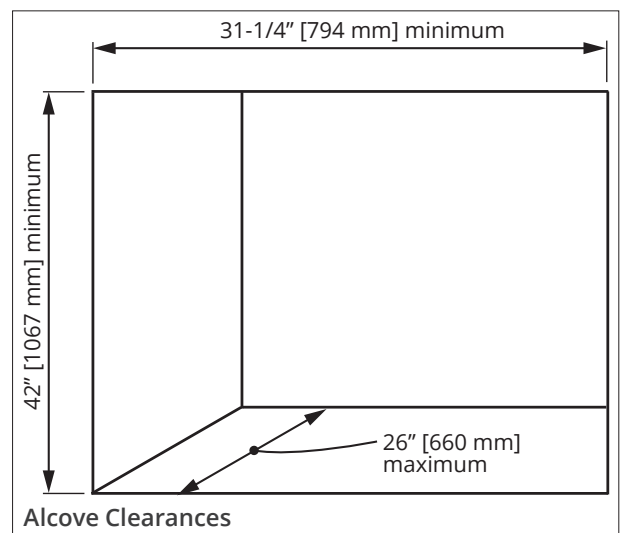
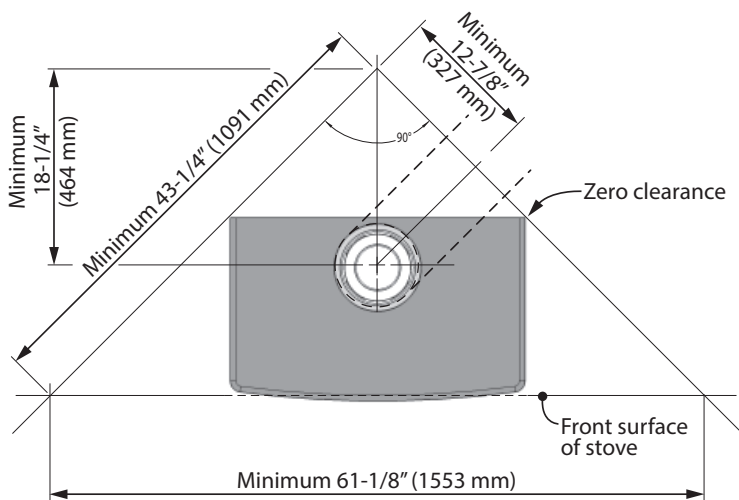
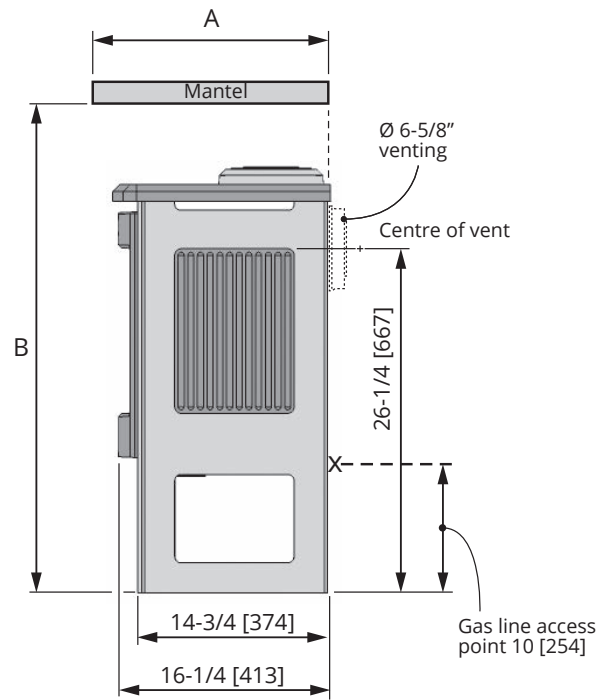
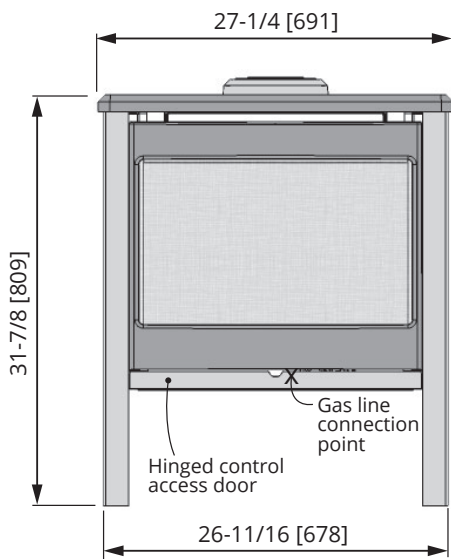

Corner clearances

Top or Rear Facing Take-Off

This appliance is supplied with a top facing take-off which may be converted to a rear facing one with no extra parts required—see *Vent Outlet* page 22 for details.

Vent Material

This appliance is approved for installation using 4 x 6-5/8-inch co-axial direct vent pipe and accessories as listed in *Approved Venting Components* pages 37–38.

This appliance may also be converted to co-axial flex 3 x 5 for use in solid-fuel burning fireplaces and chimneys using approved adapters and accessories. See *Co-Axial Flex Conversion* pages 17–19 and *Approved Venting Components* pages 37–38.

Follow the installation instructions supplied with the individual venting accessories.

Do not cut pipe lengths; use adjustable lengths instead.

Vent Sealing

Seal all **outer** co-axial pipe and elbow joints, including sectioned elbow joints, using high quality, high temperature 2-inch wide self-adhesive aluminum foil tape (Nashua-322-2 brand or similar). Wrap the tape completely around all **outer** joints and press firmly to seal.

A high-temperature black silicone sealant may be used in the **outer** joints as a substitute to foil tape.

Ensure all the pipe joints have a minimum of 1-1/4 inch overlap.

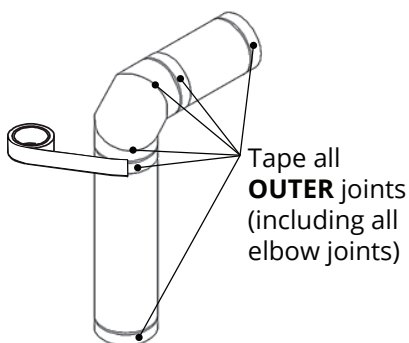

Wall Thickness

The appliance vent is suitable for penetrating a combustible wall assembly up to 14 inches in thickness. A non-combustible wall can be of any thickness up to the maximum horizontal run of vent pipe allowed for the particular installation.

Framing Vent in Combustible Walls & Ceilings

When penetrating through combustible walls and ceilings, frame a minimum of 10 inches x 10 inches opening and ensure that the insulation is kept clear of the vent pipe using either a wall thimble or an attic insulation shield. Also, seal all joints between the wall plates, the wall and the vent pipe. Follow the installation instructions supplied with the individual venting components.

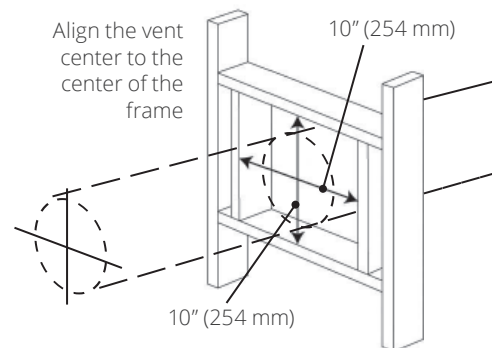

All horizontal pipe runs must be graded 1/4 inch per foot upwards in the direction of the exhaust flow. The final pipe length, when terminating through the wall may be graded downwards slightly to prevent water migration.

Important Installer Notice— Weather Sealing & Vapor Barrier

It is the installer's responsibility to ensure that vent installations through exterior walls are caulked and weatherproofed in such a manner as to:

- Prevent rain from entering the wall from the weather side by adequately caulking the outer vent plate to the exterior wall surface.
- Prevent moisture inside the home from penetrating into the wall structure by ensuring the inside wall plate is adequately sealed to the inside vapor barrier.
- Prevent rain water and moisture from entering the walls by sealing the joints between the outer vent tube and the inner and outer wall plates.

We recommend the use of a high quality polyurethane sealant.

Venting

Co-Axial

Typical Co-Axial Venting Components

See venting accessories list on pages 37-38 for allowable components.

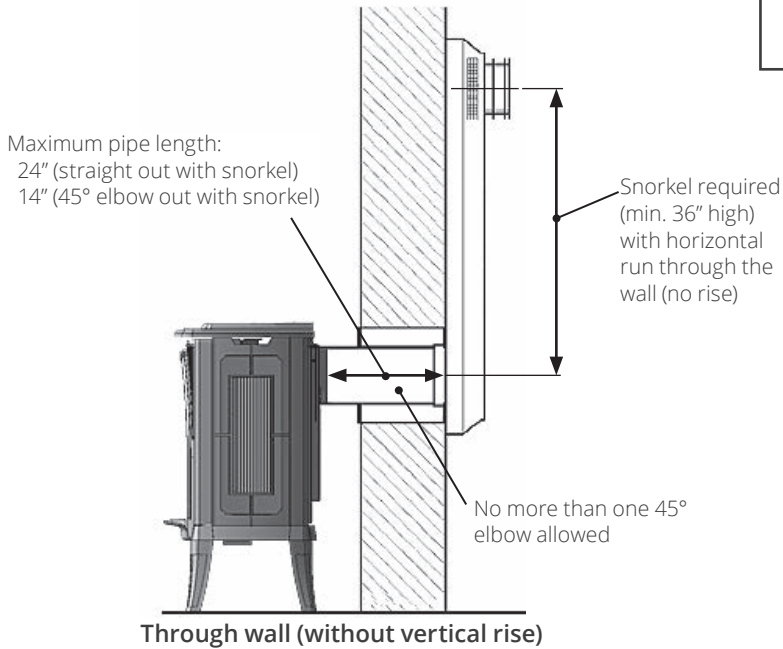

IMPORTANT

Provide support for vertical pipe runs, particularly offsets. Do not rely on the appliance for support of long vertical pipe runs. Horizontal pipe runs should be supported every 4 feet using strapping.

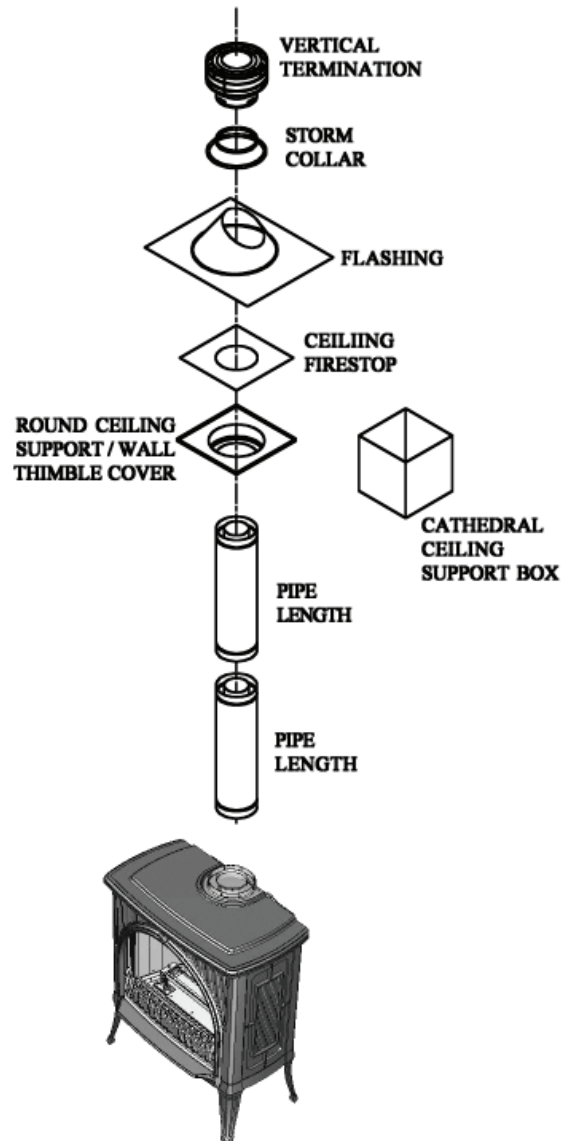
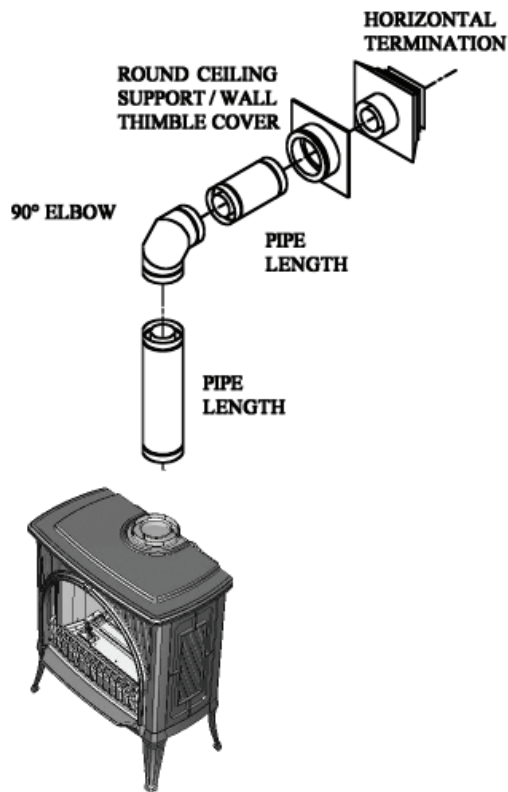

Through wall (with vertical rise)

Through roof

Venting Chart

How to Read the Venting Charts

The chart below applies to co-axial roof or wall termination in installations **with vertical rise**.

All rear venting without a vertical rise must be terminated by a 36" snorkel—see page 11.

1. The total length of the vent pipe cannot exceed 40 feet.
2. The minimum vertical height with roof termination is 8 feet.
3. Any combination of rise and run can be used as long as they are within the allowable limits shown on the chart.
4. A maximum of 5 x 90 degrees elbows—or equivalent (2 x 45 degrees = 90 degrees)—can be used.
5. Each 90 degrees elbow installed on the horizontal plane is equivalent to a 3 feet horizontal pipe; therefore, 3 feet must be subtracted from allowable horizontal run. (45 degrees elbow is equivalent to 18 inches horizontal pipe.)
6. All horizontal pipe runs must be graded 1/4 inch per foot upwards in the direction of the exhaust flow. The final pipe length, when terminating through the wall may be graded downwards slightly to prevent water migration.
7. **Maximum co-axial flex venting** in existing chimney systems is limited to 40 feet vertical rise.
8. **Restrictors are required for co-axial flex installations.**

Allowable Co-Axial Vent Configurations with restrictor positions

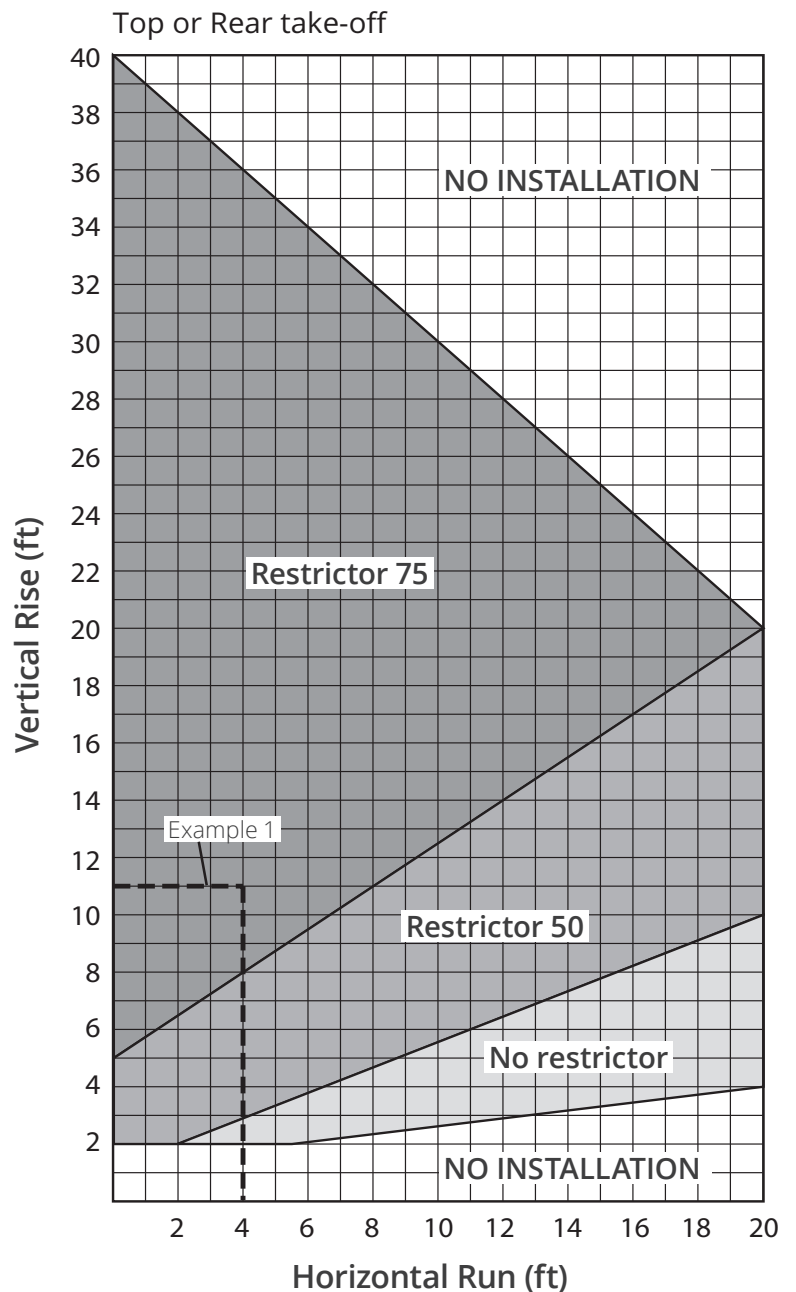

Venting

Co-Axial

Venting Diagram

5 x 90° ELBOWS MAXIMUM
(or equivalent)

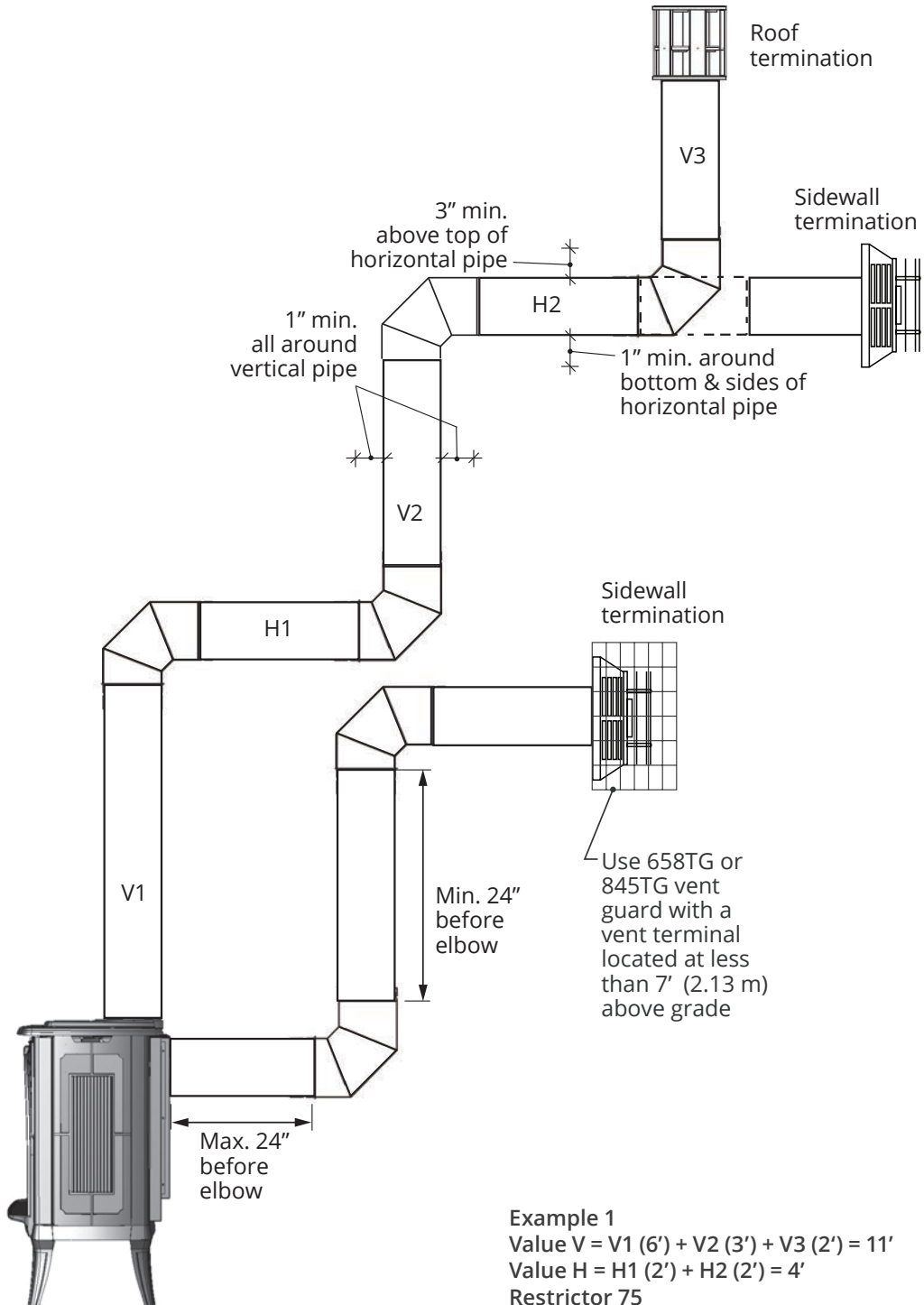

Not to scale

Restrictors

SOME INSTALLATIONS REQUIRE RESTRICTORS. For improved flame picture and performance, this unit is supplied with two different sets of vent restrictors. The level of restriction required depends on the vertical rise in the venting system and, to a lesser degree, the horizontal run and number of elbows.

The amount of restriction is based on laboratory tests.

The ideal restrictor set may vary, especially when the vent pipe length is near the limits of the acceptable configurations for each type of restrictors.

The chart on page 12 shows the vent restrictor required relative to the length of the vent pipe.

Restrictors are required for co-axial flex applications.

To install restrictors:

1. Remove every second screw from the exhaust ports in the top of the firebox.
2. Fit the restrictors and secure with the removed screws.

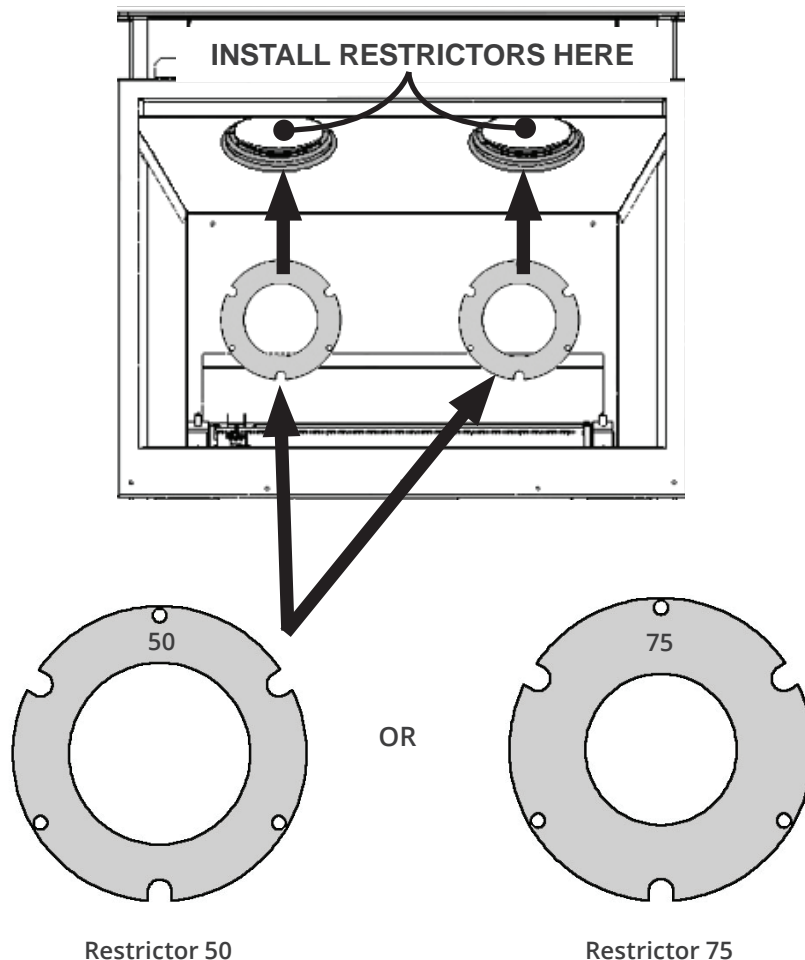

Horizontal Vent Termination Location

- The vent terminal must be located on an outside wall or through the roof.
- This direct vent appliance is designed to operate when an undisturbed airflow hits the outside vent terminal from any direction.
- The minimum clearances from this terminal that must be maintained when located on an outside wall are shown in figure below. Any reduction in these clearances could result in a disruption of the

airflow or a safety hazard. Local codes or regulations may require greater clearances.

- The vent terminal must not be recessed into a wall or siding.
- The vent terminal should be positioned where any snowdrifts will not cover it.
- Sidewall vent terminations require a terminal guard such as 658TG or 845TG when accessible—within 7' of ground.

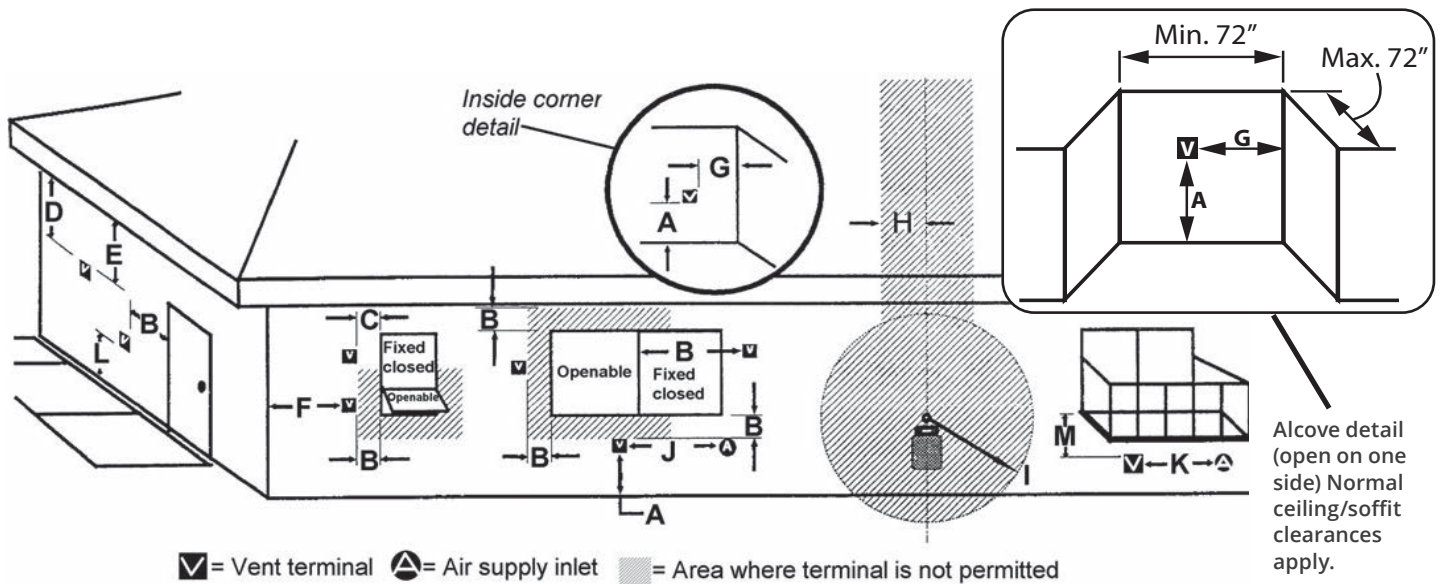

KEY	VENT TERMINAL LOCATIONS - MINIMUM DISTANCES	MINIMUM CLEARANCE	
		Inches	Cm
A	Clearance above grade, verandah, porch, deck or balcony	12	30
B	Clearance to window or door that may be opened	12	30
C	Clearance to permanently closed window (recommended to prevent condensation on window)	12	30
D	Vertical clearance to ventilated soffit located above the terminal within a horizontal distance of 2 feet (60 cm) from the center-line of the terminal	18	46
E	Clearance to unventilated soffit	12	30
F	Clearance to outside corner (measured from the center of vent)	12	30
G	Clearance to inside corner (measured from the center of vent)	12	30
H	Horizontal clearance to center-line of meter/regulator assembly located within 15 feet (4.6 m) below the terminal	36	90
I	Clearance to service regulator vent outlet	36	90
J	Clearance to non-mechanical air supply inlet to the building or the combustion air inlet to any other appliance	12	30
K	Clearance to a mechanical air supply inlet	72	180
L	Clearance above paved sidewalk or a paved driveway located on public property Note: A vent must not terminate directly above a sidewalk or paved driveway, which is located between two single-family dwellings and serves both dwellings. THIS DOES NOT APPLY to direct vent, non-condensing appliances in the Province of Ontario.	84	210
M	Clearance under a verandah, porch, deck or balcony Only permitted if veranda, porch, deck or balcony is fully open on a minimum of 2 sides beneath the floor	12	30

Note: Local codes and regulations may require different clearances.

Vertical Vent Termination

Roof Pitch	Minimum "H" [feet]
Flat to 7/12	1'
Over 7/12 to 8/12	1.5'
Over 8/12 to 9/12	2'
Over 9/12 to 10/12	2.5'
Over 10/12 to 11/12	3.25'
Over 11/12 to 12/12	4'
Over 12/12 to 14/12	5'

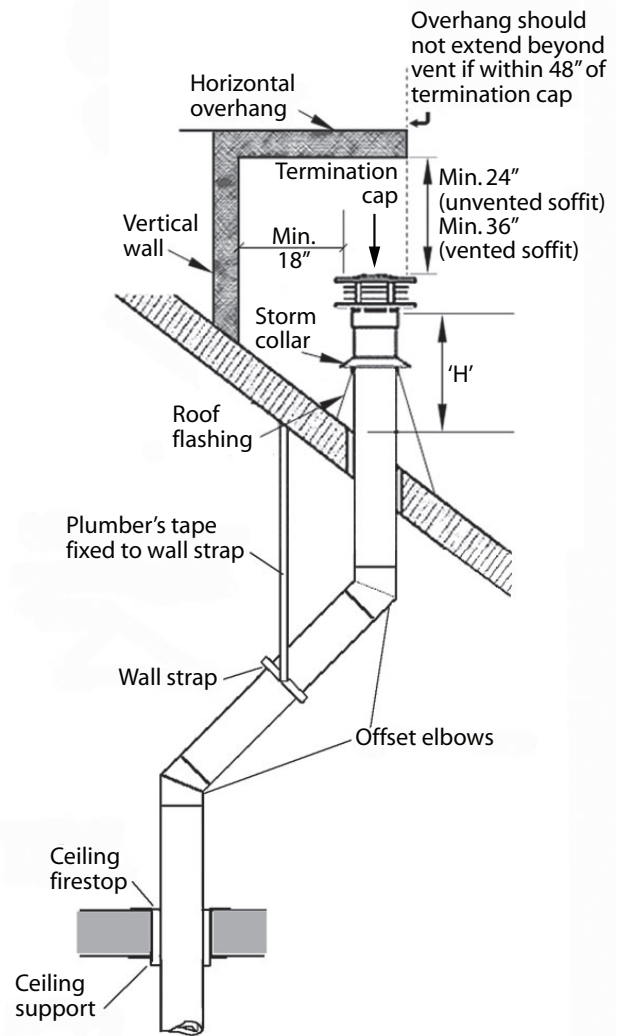

Through-the-roof installation

Venting

Co-Axial Flex Conversion

Applications

This appliance can be converted to install as a co-axial using flex pipes application. The co-axial flex portion of the vent system may only be installed within a solid-fuel burning appliance.

This appliance must not be connected to a chimney flue serving a separate solid-fuel burning appliance.

Types of Installations

- Complete installation into an existing fireplace
- Partial installation into an existing fireplace
- Installation into an adjacent chimney

See the following pages for each installation details.

Rules for Co-Linear Venting

- Maximum 40 feet vertical pipe
- Minimum 10 feet vertical
- Maximum offset 8 feet with liners at minimum 45 degrees from horizontal plane
- Restrictor: Use restrictors #75. See *Restrictors* page 14.

NOTE

Co-axial flexible aluminum venting liners should be professionally inspected periodically for corrosion and damage and replaced when necessary. If the installation does not allow for future inspection or replacement of the flexible aluminum liners, then stainless steel vent liners are recommended.

Existing Fireplace Preparation

A few points must be considered before inserting the MF28 into an existing fireplace cavity. Generally, no modifications are allowed to the existing fireplace that will compromise the integrity of the existing fireplace.

Cutting away any sheet metal parts of the existing fireplace to accommodate the installation of the MF28 is prohibited. Check with local authorities if in doubt.

Components that are bolted or screwed on such as dampers or baffles may be removed to accommodate the installation of the MF28 engine. Refractory bricks, glass doors, screen rails, screen mesh, and log grates can be also removed.

Clean Fireplace and Chimney

Have the chimney swept and the fireplace cavity including ash dumps and clean-outs cleaned before installing the MF28 heater and vent liners. Any creosote or soot residue remaining in the fireplace cavity chimney or clean-out may cause odors or stains once the MF28 insert is installed. Consult with chimney sweep for information on how best to clean.

Existing Dampers

Factory-built, zero-clearance fireplaces will require the damper to be removed in order to install the vent liners. These dampers are usually bolted into place. Dampers in masonry fireplaces must be fixed open and may remain in place.

Ash Retaining Curbs

Some fireplaces (particularly factory-built) have a raised curb at the front edge to retain ashes. Check the dimensions carefully to ensure the MF28 engine will fit behind any raised curb (some curbs may be removed separately from the refractory base).

Gas Line Routing

Plan the routing of the gas line before proceeding. Utilize the existing hole for the gas line of the factory-built fireplace.

If the fireplace has no access hole, carefully drill an access hole of 1.5 inch (37.5 mm) or less through the lower sides or bottom of the firebox in a proper workmanship manner. This access hole must be plugged with non-combustible insulation after the gas supply line has been installed.

See *Dimensions* section for detailed location of gas inlet. Also, take into consideration whether or not a fan or shut-off valve will interfere when planning routing of the gas line.

Combustible Mantels

Combustible mantel clearances must conform to those required for the original solid-fuel fireplace into which the MF28 is being installed.

Attach Warning Conversion Plate to Existing Fireplace

(Label supplied with vent adapter)

Attach the "This fireplace has been converted..." label to **the existing fireplace** using screws or other mechanical means and store any removed parts in back of the existing fireplace for future use.

Venting

Co-Axial Flex Conversion

Partial Installation Into an Existing Chimney or Into an Adjacent Chimney with 590CFA

The appliance's venting system can be partially inserted into the non-combustible adjacent chimney as illustrated below.

In this case, the appliance must maintain clearances to combustibles as shown in this manual.

Required venting components:

- Valor 590CFA—Co-axial 4 x 6-5/8 to 3 x 5 vent adapter;
- Valor 590FVK2 Flex Vent Kit;
- High wind vertical co-axial vent terminal cap or low profile co-axial vertical termination.

NOTE

This appliance must maintain clearances to combustibles as shown in this manual.

NOTE

See 590CFA and 590FVK2 installation manuals for complete instructions.

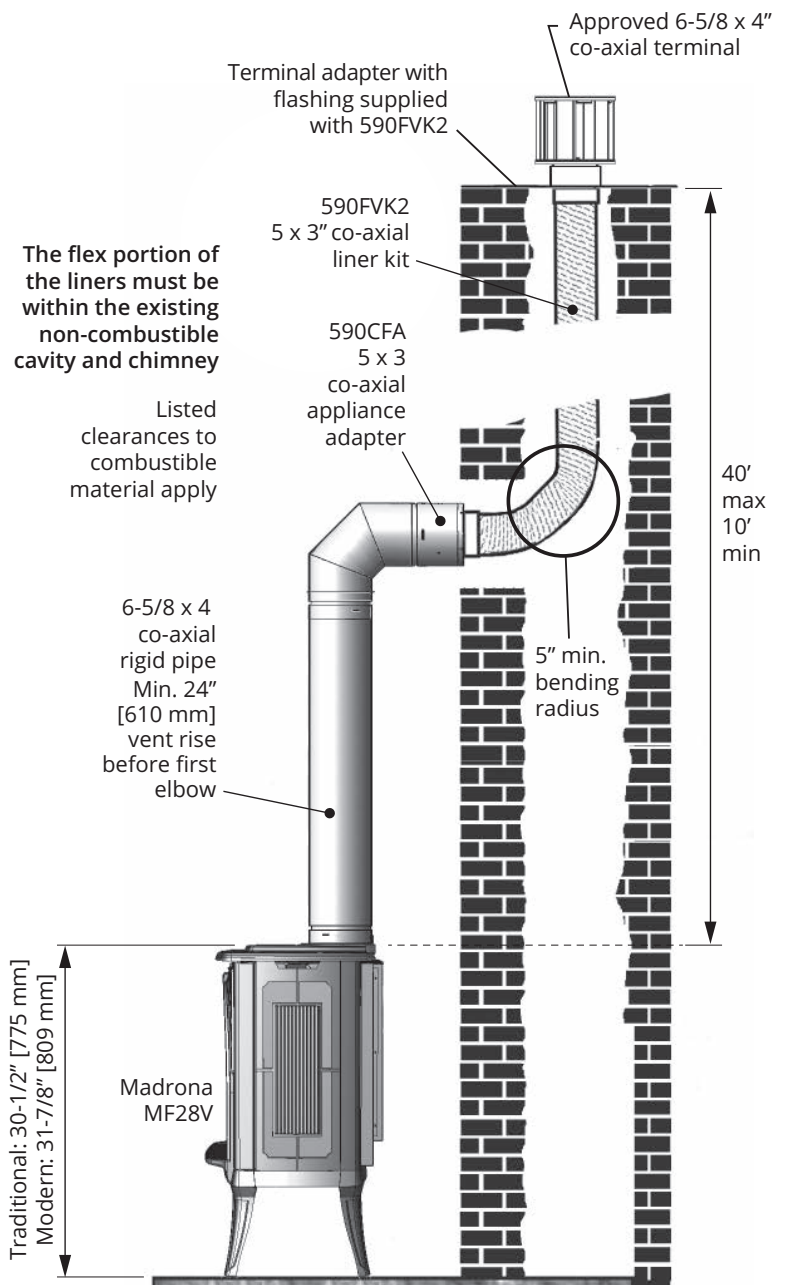
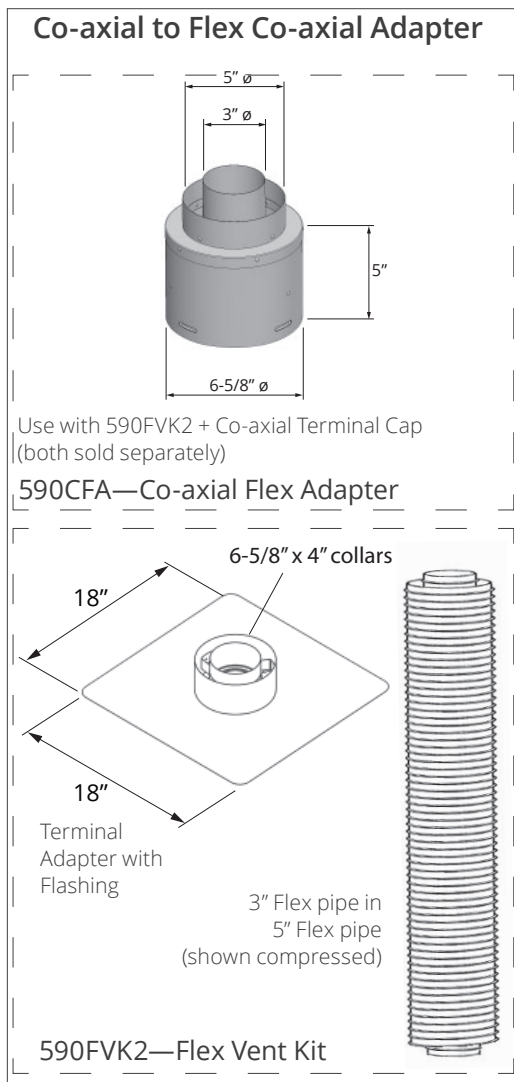

Venting

Co-Axial Flex Conversion

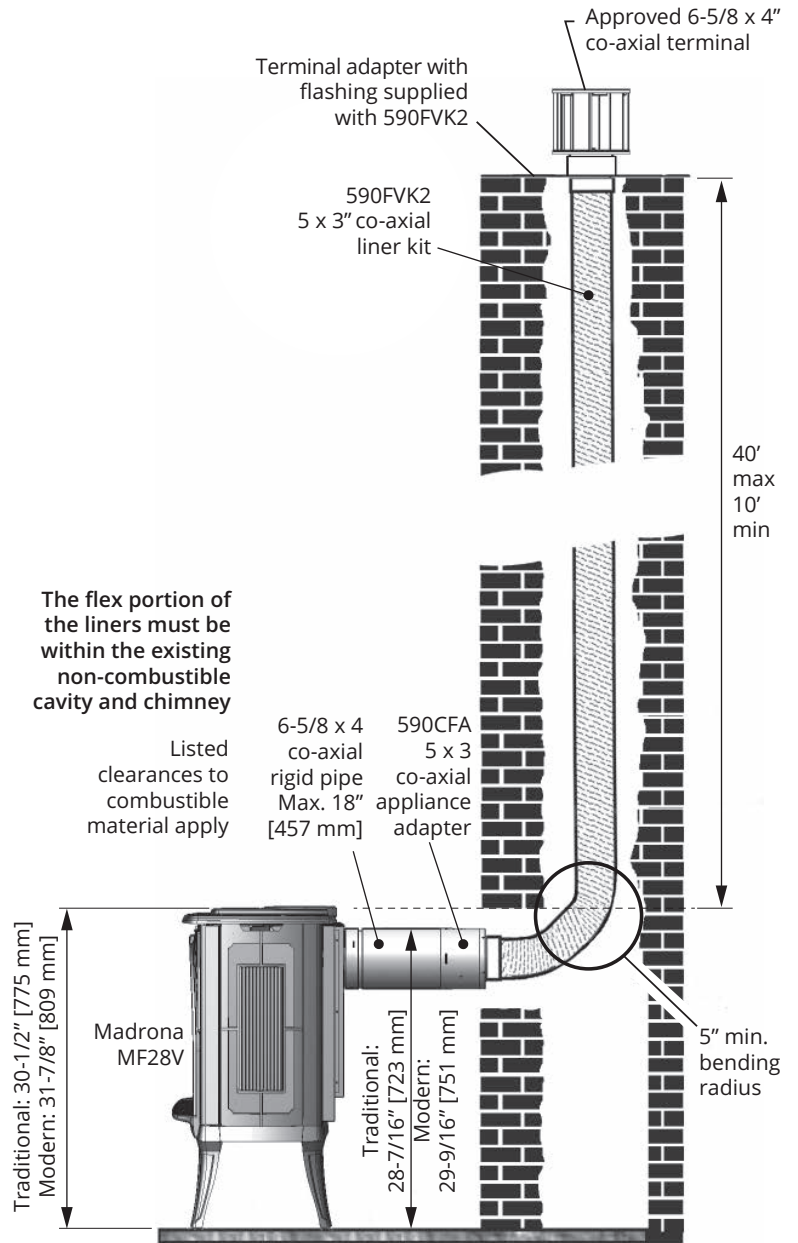
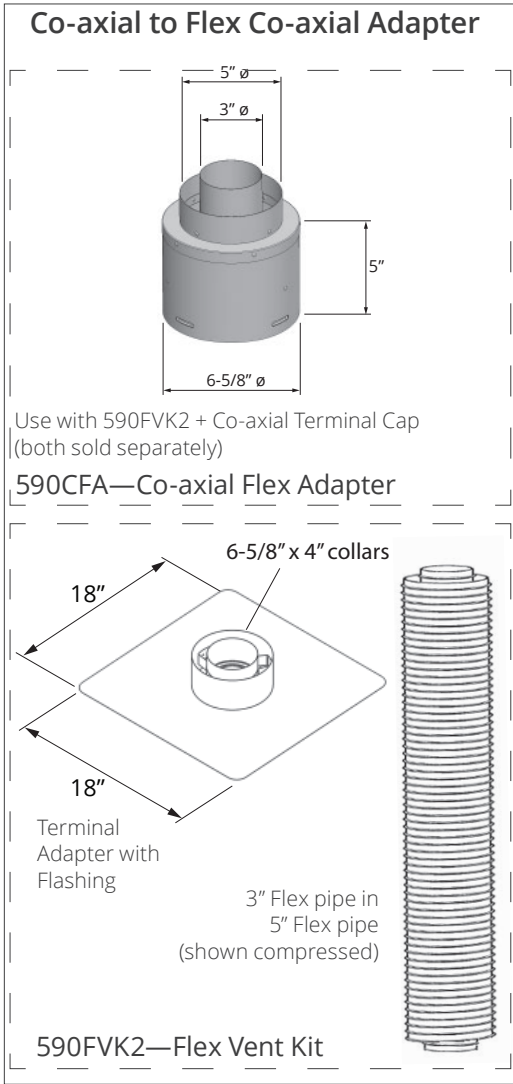

Preparation

Before Installing



Attention

ONLY qualified licensed or trained personnel should install this appliance.

1. **BEFORE YOUR START, YOU NEED TO KNOW FROM THE HOMEOWNER:**
 - Required accessories to install with stove: fuel bed, fan, venting accessories;
 - Hearth, if used;
 - Venting configuration.
2. Unpack the appliance however keep it on its packaging base to avoid damaging the components underneath. Removing all items packed inside and around it. Recycle packaging.
3. Check that you have everything required for the installation, using the Pack Content sheet. Also, check that you have:
 - Fuel bed (packed separately);
 - Stove casing with barrier screen (in multiple cartons);
 - Venting accessories;
 - Gas conversion kit, if necessary;
 - Fan, if necessary;
 - Electrical accessories, if fan is used.
4. **Carefully read the Installer's Checklist included with the appliance for the installation sequence. Read also this manual and the stove casing manual to have all information necessary for the installation.**

Installation Considerations

Fan (Blower)

Allow for and install electrical wiring if there will be a fan (blower) to install. Ask the homeowner if you are not sure.

Venting Configuration

This unit is supplied with a top vent take-off and is field convertible to a rear vent take-off. Plan routing of vent taking into consideration stove and vent clearances, allowable vent terminal locations **BEFORE** cutting a hole in the roof or wall. Avoid penetrating the wall/roof at structural members.

Gas Line Routing

Consider visibility of shuf-off or step-down regulators, etc. when planning gas line routing.

Upack Appliance

The Madrona appliance is supplied separately from the stove casings. The Traditional stove—MFCS01 (black) or MFCS02 (majolica brown)—and the Modern stove MFCS05 are each supplied in multiple cartons. You must have in hand the stove casing before starting the assembly of the appliance.

Unpack the cartons carefully. **We strongly recommend that you leave the appliance sitting on the packaging base in which it came to avoid damaging the control valve, wires and pipes already attached until it is ready to install in the stove casing.**

Some parts are packed in the cardboard sleeve around the appliance; make sure you take them all out of the packaging. Make sure you have all the components including the stove casing components before you start the installation



Caution

LEAVE THE APPLIANCE ON ITS PACKAGING BASE to avoid damage to the control valve, wires and pipes until ready to install into stove casing.

Installation

Remove Window

It is easier to remove the window and all the items packed inside of the firebox to make the engine lighter for installation.

1. Release the spring bolts at top and bottom of the window by pushing and turning 1/4 turn.

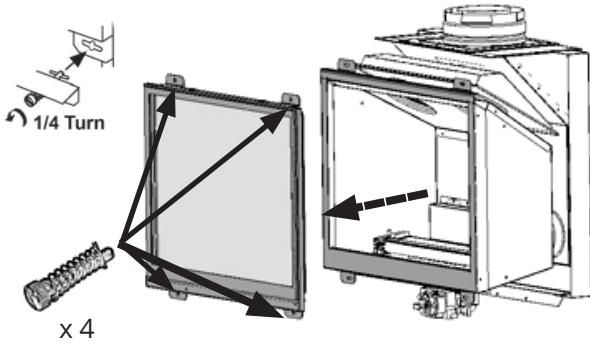

2. Lift the window and set it aside in a safe place to avoid damage.

Unpack Stove Casing

1. Rough-in the gas line and electrical wiring for a fan if any.
2. Decide where the stove should be positioned to avoid moving it once all the casing is put together.
3. Unpack the casing and follow the instructions supplied with each model (MFCS01, MFCS02 or MFCS05).

Reposition Lighting Instructions Plate

Roll the lighting instructions cards and tucked in at the rear above the angled flange or fan (if installed).

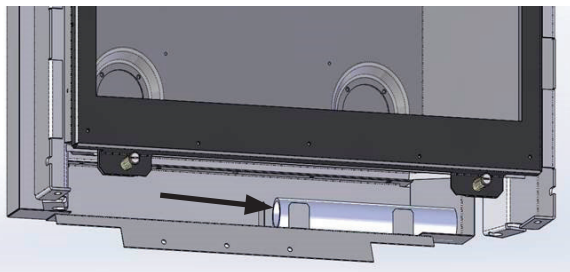

Window & Optional Fan

Unclip Remote Control Receiver

Under the appliance, the receiver box is clipped to the burner pipes to facilitate transportation. Unclip the box and let it hang while you fit the gas pipe.

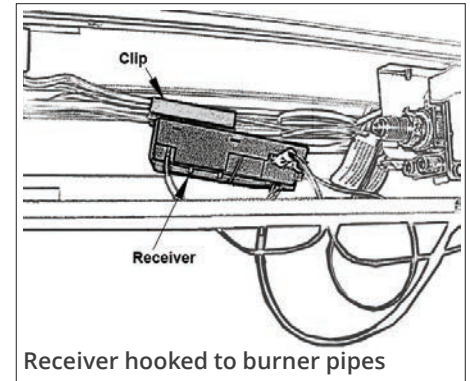

Install Optional Fan (if required)

If this installation requires the optional fan, it is easier to install it at this point.

1. Remove the mounting plate from the fan and discard it.

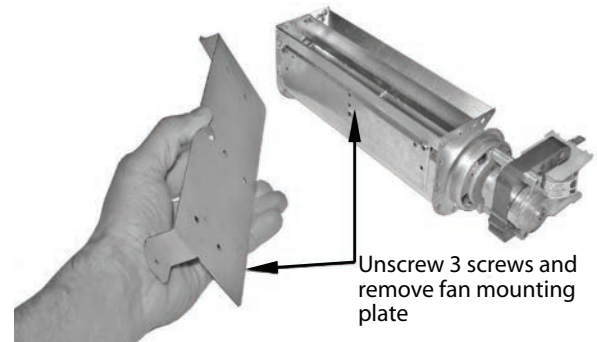

2. Install the fan motor at the back of the heater. Using the lower set of fixing holes on the fan will ensure more space to handle the receiver in front of the fireplace.

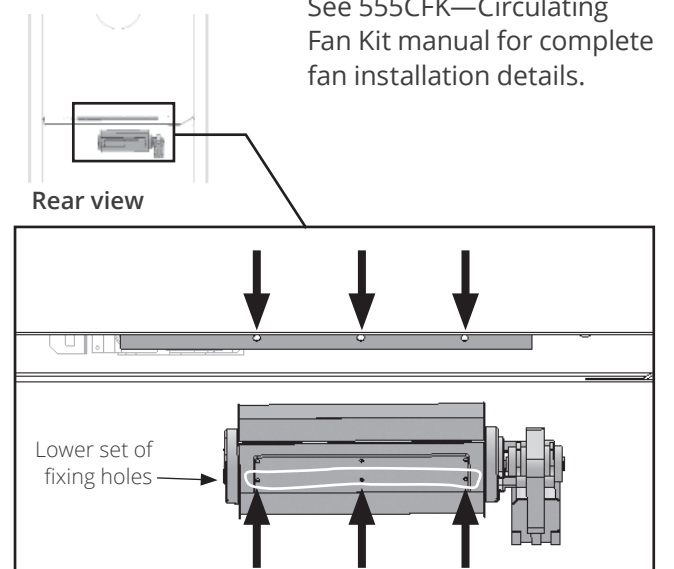

Installation

Vent Outlet

Install Gas Pipe & Connector

The gas pipe, connector, clamp and fixing screw are supplied with the engine.

The support bracket for the gas pipe is supplied with the stove casing.

NOTE

The support bracket used on Madrona Traditional stoves and the one used on Madrona Modern stoves are different. Refer to stove casing installation manual for complete details.

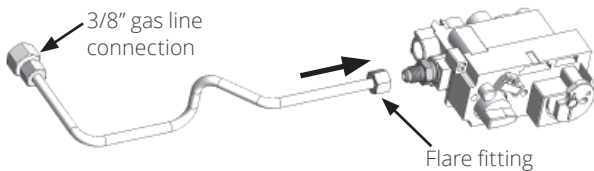

Install Receiver into Position

Once the gas pipe is fitted, clip the receiver on top of the casting crossbar on the base, to the left hand side of the valve. Make sure the receiver box is oriented with its wires towards the back and its RESET button at the front.

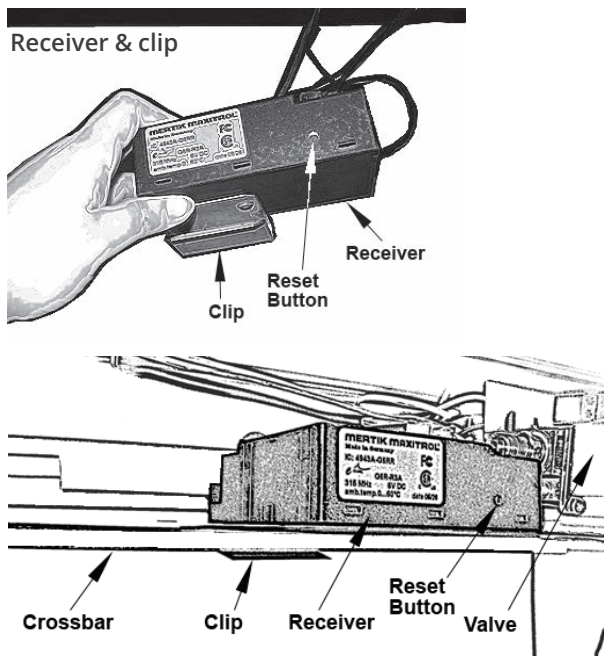

Receiver clipped to crossbar in final position

Convert Vent Outlet (if necessary)

Rear Vent

If the appliance is to be vented from the top, it is ready for vent installation once the engine is on the casting base.

If the appliance is to be vented from the rear, it must be converted. Follow these simple steps:

1. Remove the following parts in this order:
 - a. Dura-Vent collar, gasket and intake plate from the top of the appliance (22 screws of the intake plate and 2 rear screws of the collar);

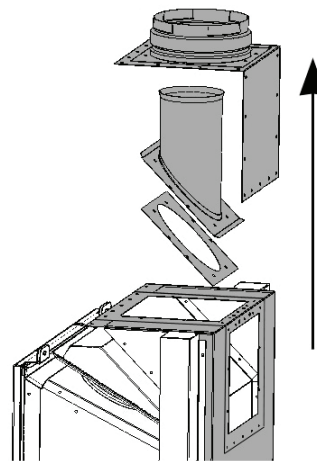

- b. Exhaust collar (8 screws). Note that the gaskets are glued to the appliance or the intake plate; it is not necessary to separate them from the parts they are attached to. However, if they need to be manipulated, **BE CAREFUL not to damage them because their material is fragile.**
2. Reinstall through the vent opening at the rear of the firebox in the reverse order in which you took the parts out.

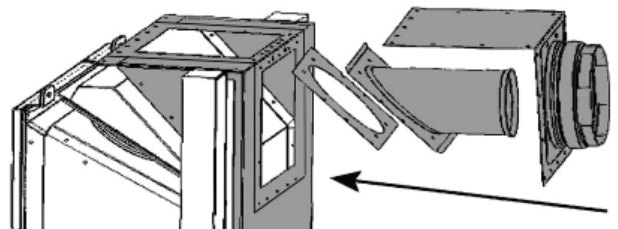

Co-Axial Flex

For conversion to co-axial flex venting (3 x 5), see pages 17-19 and refer to instructions packaged with the 590CFA + 590FVK2 kits.

Installation

Gas Supply

Connect Gas Supply

The gas supply inlet connection is a 3/8 inch NPT female connector. If a circulating fan or isolating valve is to be installed, adjust the routing of the gas line to suit.

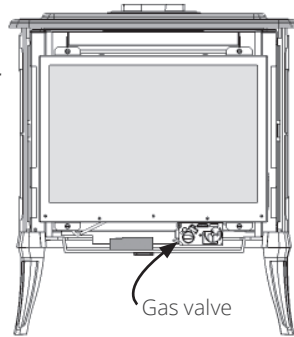

Use only new black iron or steel pipes, CSST, or copper tubing if acceptable—check local codes. **Note that in USA, copper tubing must be internally tinned for protection against sulfur compounds.**

Union in gas lines should be of ground joint type.

The gas supply line must be sized and installed to provide a supply of gas sufficient to meet the maximum demand of the appliance without undue loss of pressure.

Sealant used must be resistant to the action of all gas constituents including propane gas. Sealant should be applied lightly to male threads to ensure excess sealant does not enter gas lines.

The supply line should include a **manual shut-off valve** and **union** to allow the appliance to be disconnected for servicing.

Pressure test the supply line for leaks.

The appliance and its individual shut-off valve must be disconnected from the gas supply piping system during any pressure testing of that system at test pressures in excess of 1/2 psig (3.5kPa).

The appliance must be isolated from the gas supply piping system by closing its individual manual shut-off valve during any pressure testing of the gas supply piping system at test pressures equal to or less than 1/2 psig (3.5kPa).

Failure to either disconnect or isolate the appliance during pressure testing may result in regulator or valve damage. Consult your dealer in this case.

The minimum supply pressure is given on page 6 of this manual.

All piping and connections must be tested for leaks after installation or servicing. All leaks must be corrected immediately.

When testing for leaks:

- Make sure that the appliance is turned off.
- Open the manual shut-off valve.
- Test for leaks by applying a liquid detergent or soap solution to all joints. Bubbles forming indicate a gas leak.

WARNING

NEVER USE OPEN FLAME to check for leaks. Correct any leak detected immediately.

The pressure test tapping locations are shown below. A built-in non-adjustable regulator controls the burner manifold pressure. The correct pressure range is shown page 6 of this manual. The pressure check should be made with the burner alight and at its highest setting. See *Appendix A – Lighting Instructions Plate* page 40 for full operating details.

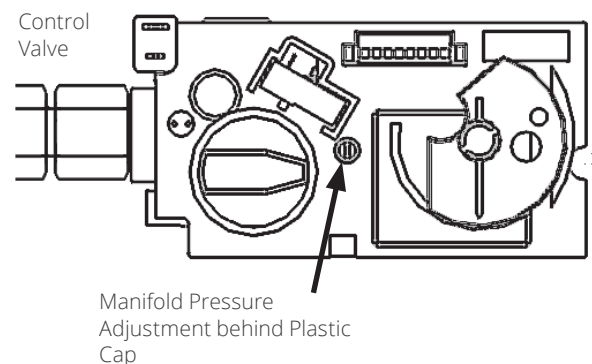
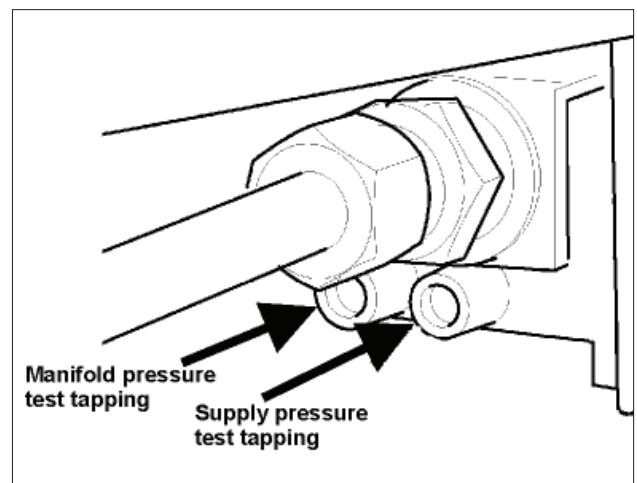

Installation

Fuel Beds

Traditional Log Set MF28VLSK

Material required

- Traditional Log Set containing:
 - 7 logs
 - Embers, bagged
- Gloves, if desired (not included)

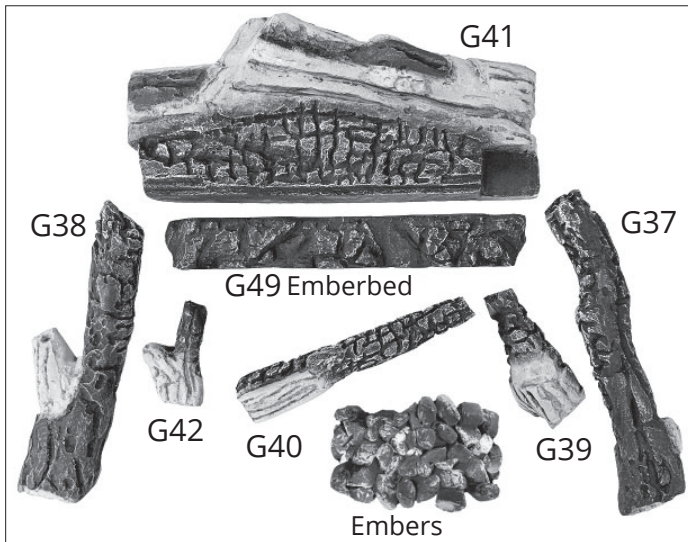

Installation

Unpack the ceramic logs very carefully to avoid damaging their fragile material. Install the logs as shown below. Please note that the position of the logs is critical to ensure the good performance of the appliance.

1. Place a single layer of embers in front of the burner leaving a space at each end as shown.



2. Place log G41 behind the burner and slide it to the right to rest against the pilot area.

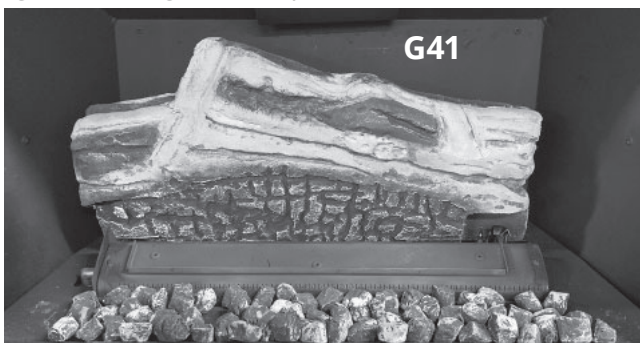

3. Place emberbed G49 directly on the burner, locating its underside groove on the vertical flange of the burner. Slide to the left.

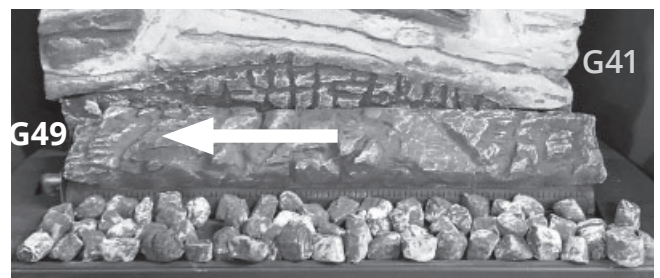

4. Place G37, the flat part of its base on the platform, right of the embers, its top into the notch on G41.

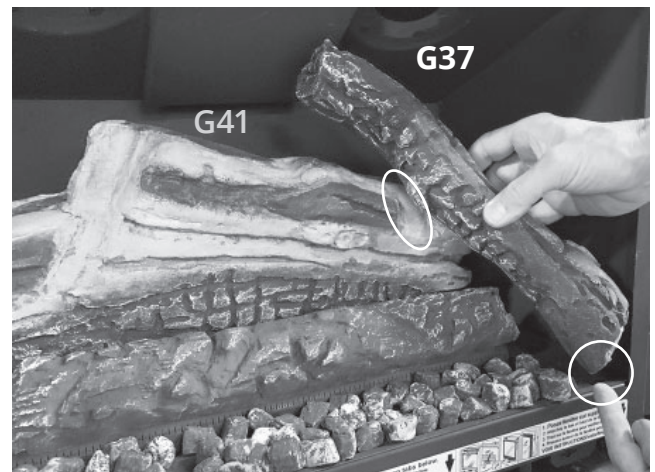

5. Place G38, the flat part of its base on the platform, left of the embers, its top into the notch on G41.

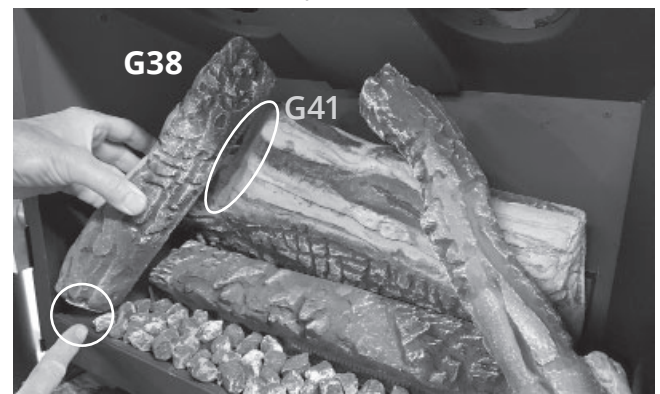

Installation

Fuel Beds

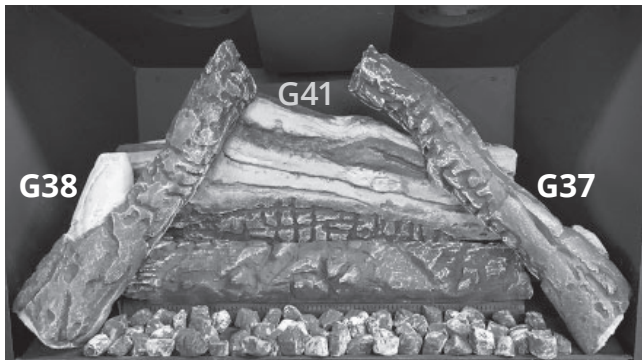

G37 and G38 installed

6. Place G39, its wide end on the embers and narrow end in the notch on the embered G49.



7. Place G40, its wide end on the embers and its narrow end in the notch on top of G39.

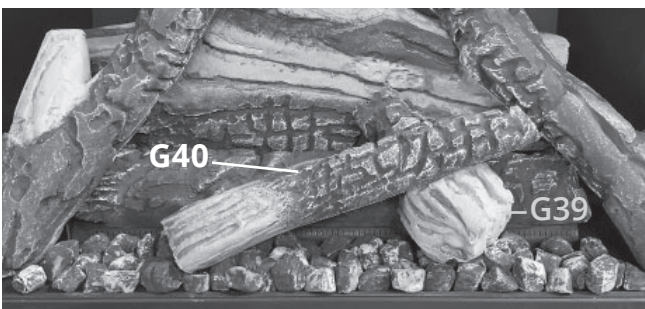

8. Place G42, its wide end on G40 and its narrow end on the embered G49.

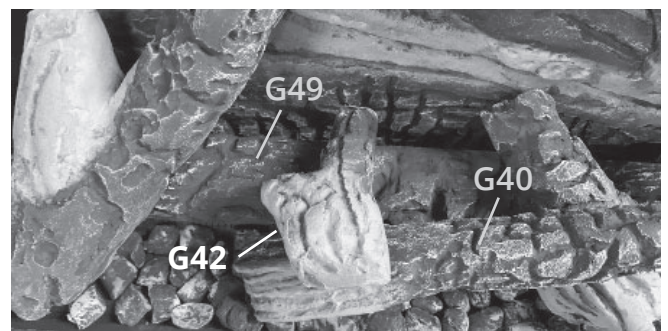
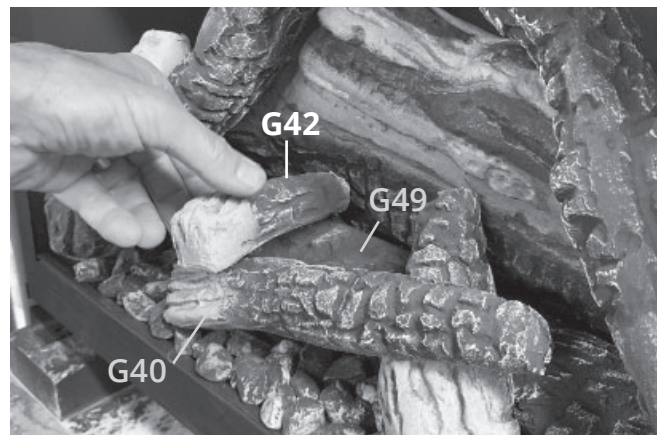

G40 installed, top view

MF28VLSK Traditional Logs installed

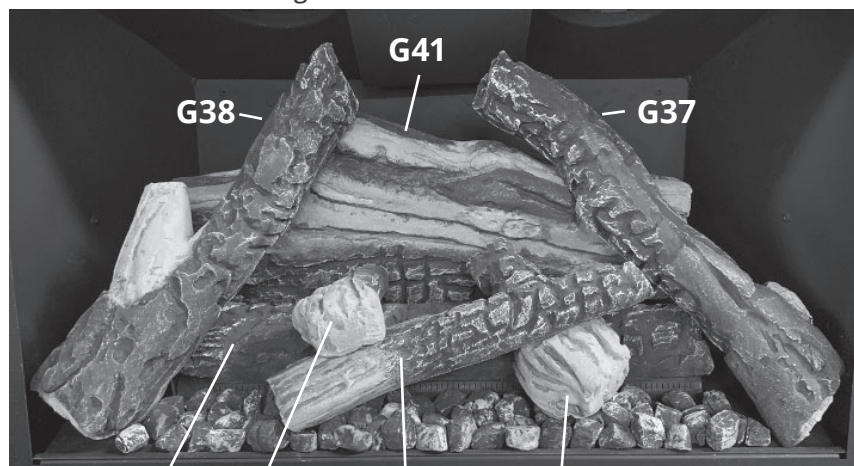

G49 G42 G40 G39

Installation

Fuel Beds

Driftwood Kit MF28VDWK

Material required

- Driftwood Kit containing:
 - 8 logs
 - 3 pebbles
- Gloves, if desired (not included)

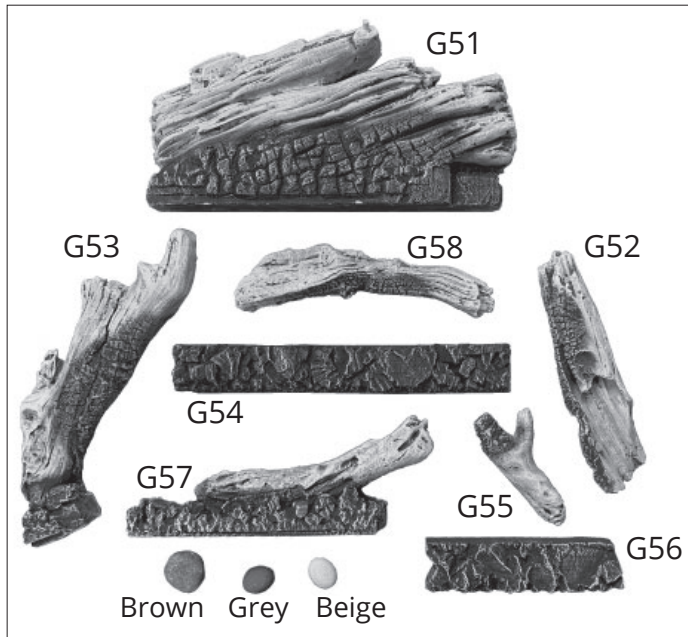

Installation

Unpack the ceramic logs very carefully to avoid damaging their fragile material. Install the logs as shown below. **Please note that the position of the logs is critical to ensure the good performance of the appliance.**

1. Place the log G51 behind the burner and slide it to the right to rest against the pilot area.



2. Place emberbed G54 directly on the burner, locating its underside groove on the vertical flange of the burner. Slide to the left.

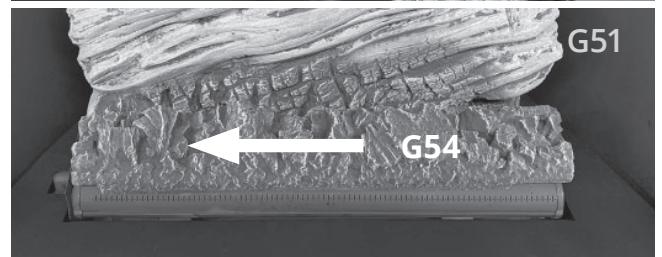
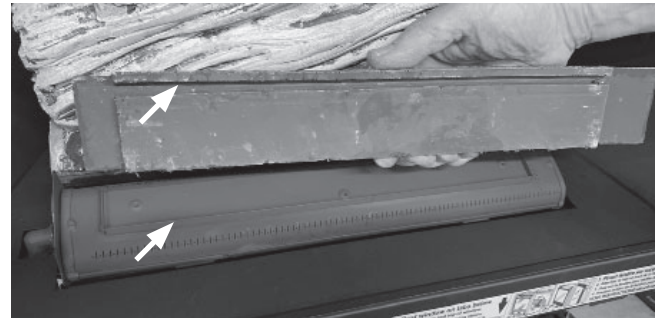

3. Place log G53, its base first against the bottom of the firebox then locating its top on the key of G51.

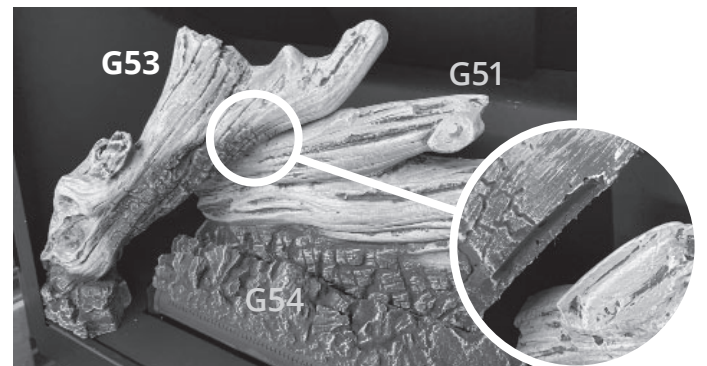

4. Place log G57 butting it against G53's base in front of the burner, along the front edge of the firebox.



Installation

Fuel Beds

5. Place G56 butting it against G57's ember base with its groove on the edge of the firebox.



6. Set G52's base in the notch of G56 and place its top in the notch on G51.

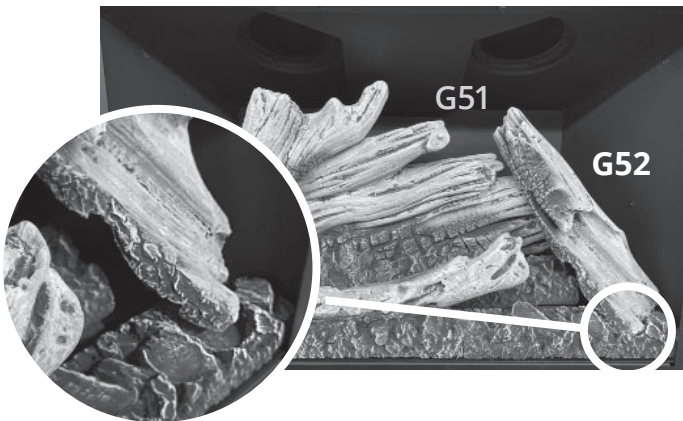

7. Place G55 in the notch on the front ember base resting its 'Y' shape on the burner emberbed. Log G57 will cover part of G55.



8. Place G58's base in the notch on top of G57 and locate its hole at the other end on the peg of G51.

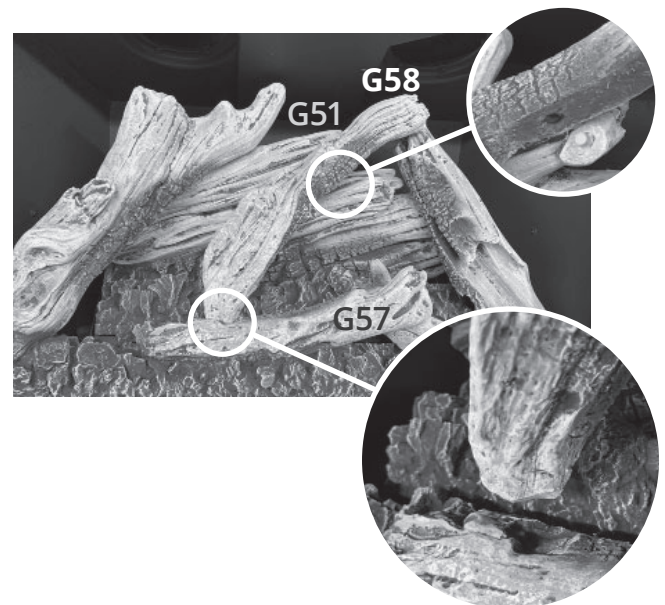

Installation

Fuel Beds

- Place pebbles in notches on the front ember base as indicated.



MF28VDWK Driftwood Kit installed



Installation

Fuel Beds

Birch Logs MF28VBLK

Material required

- Birch Logs Kit containing:
 - 7 logs
 - Embers, bagged
- Gloves, if desired (not included)

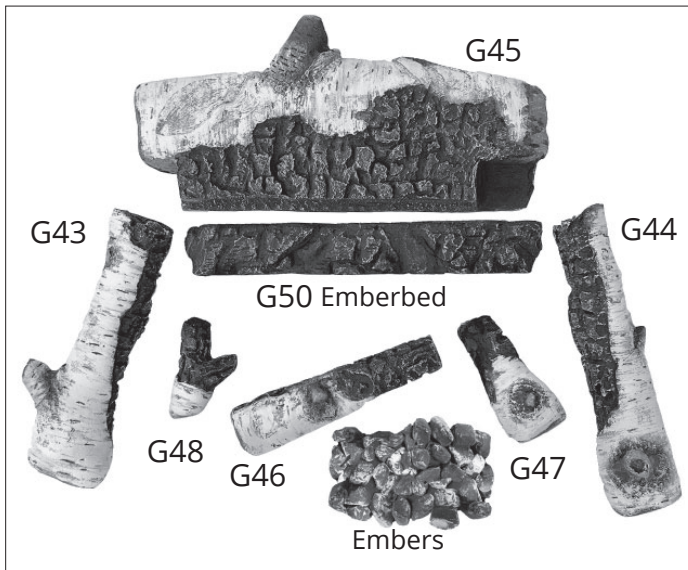

Installation

Unpack the kit carefully to avoid damaging the fragile pieces. Install the kit as shown below. Please note that the position of the logs is critical to ensure the good performance of the appliance.

1. Place a single layer of embers in front of the burner leaving a space at each end as shown.



2. Place log G45 behind the burner and slide it to the right to rest against the pilot area.



3. Place emberbed G50 directly on the burner, locating its underside groove on the vertical flange of the burner. Slide to the left.

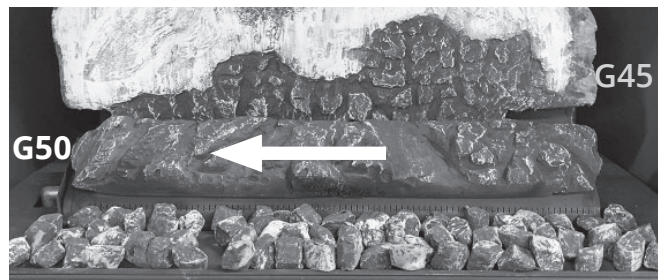

4. Place G44, the flat part at its base on the platform, right of the embers, its top into the notch on G45.

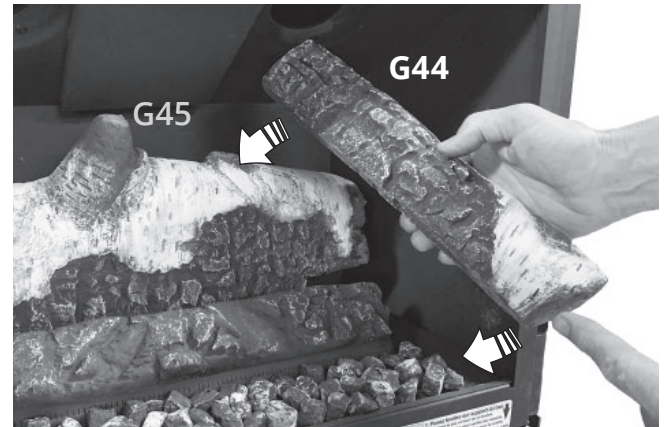

5. Place G43, the flat part at its base on the platform, left of the embers, its top into the notch on G45.

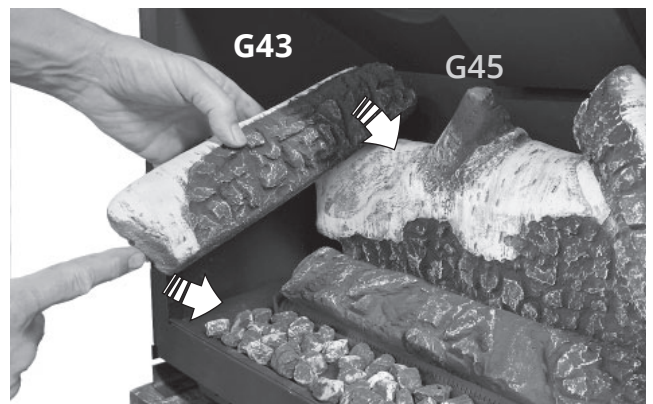

Installation

Fuel Beds

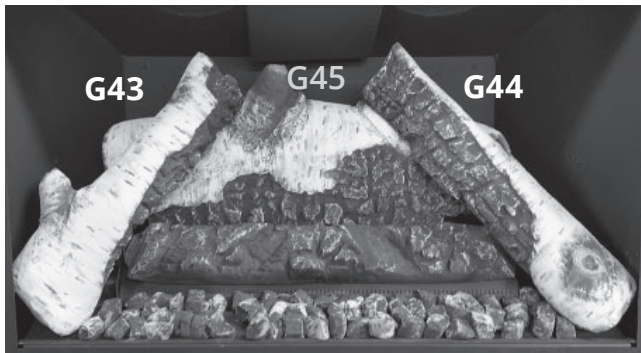

G43 and G44 installed

6. Place G47, its wide end on the embers and its narrow end on the emberbed G50.



7. Place G46, its wide end on the embers and its narrow end in the notch on top of G47.



8. Place G48, its wide end on G46 and its narrow end on the emberbed G50.

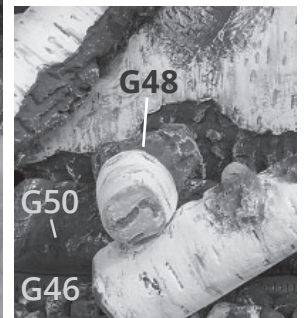
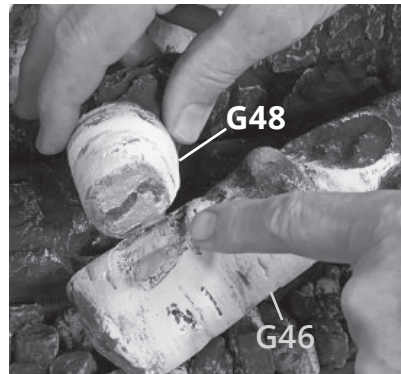

MF28VBLK Birch Kit installed

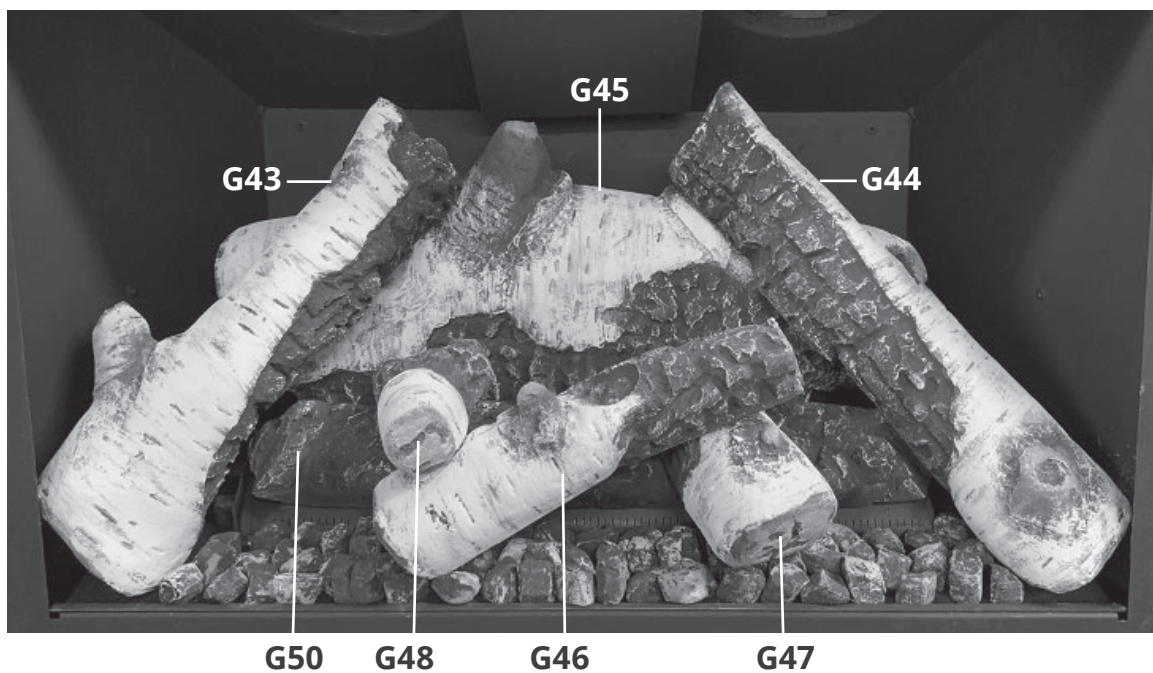

Installation

Refit & Check Window

Refit and Check Window

1. Place the window on the firebox frame and hold it in place while fastening its bolts, pushing and turning them 90 degrees. Ensure the pin at the end of the bolt is through the window fixing tabs.

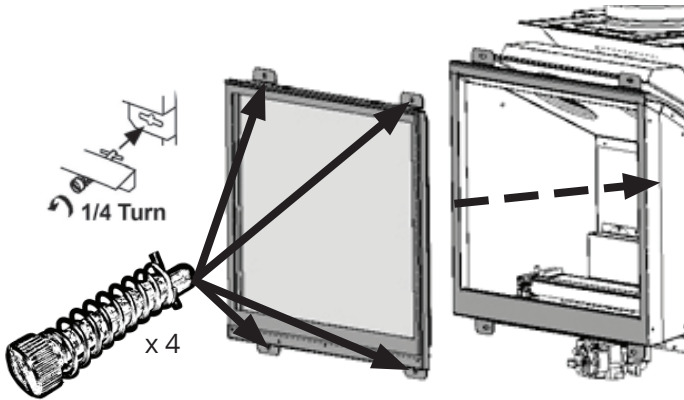

2. Pull out and release the top and bottom of the window to ensure the springs return it.
3. Apply firm hand pressure on the window frame to ensure the window is sealed tight against the firebox.
4. If the Hot Glass Warning plate has been removed from the front lower corner of the window, re-install it by sliding it between the glass and the frame as indicated.

! WARNING: EXTREMELY HOT GLASS AND FIREPLACE
Risk of severe burns. Keep Children away from fireplace & controls.
Avertissement : verre et foyer extrêmement chauds.
Risque de graves brûlures. Éloignez les enfants du foyer et des commandes.

Hot Glass Warning Plate

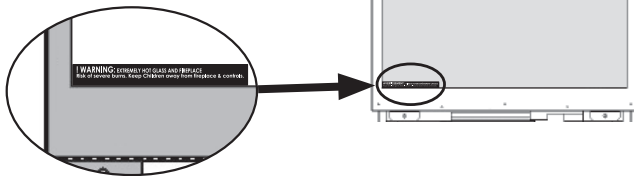

! WARNING

The window unit must be correctly installed, fastened and sealed after servicing or serious bodily injury and/or damage to the appliance may result.

To ensure a safe operation:

- Double-check that the window frame is correctly installed;
- Verify that the spring-loaded bolts are hooked properly to the window tabs then;
- Pull out and release the top and bottom of the window to ensure the springs return it;
- Ensure the window is sealed before operation.

! WARNING

Failure to install the window correctly can:

- Leak carbon monoxide;
- Affect the performance of the fireplace;
- Damage components;
- Cause overheating resulting in dangerous conditions.

Damages caused by incorrect window installation is not covered by the Valor warranty.

Installation

Battery Holder

Install Battery Holder

The batteries that power the receiver and handset need to be installed prior to pairing and use.

1. Take the receiver out from under the firebox.
2. Insert four 1.5 V new high quality **alkaline** batteries in the battery holder and one new high quality **alkaline** 9 V battery in the remote handset. The battery holder and cable are supplied with the appliance.



3. Connect the cable to the receiver as shown.

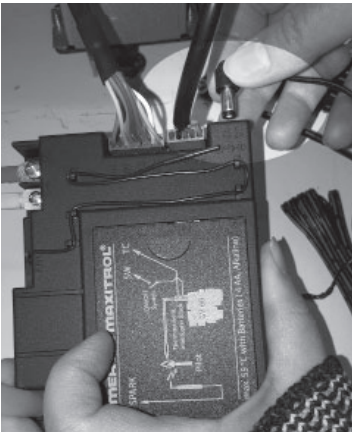

4. Connect the other end of the cable to the battery holder..

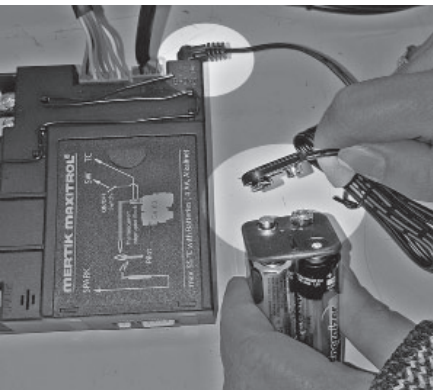

5. Place the receiver and battery holder as shown under the firebox, to the left of the control valve (placement may vary with installed options).

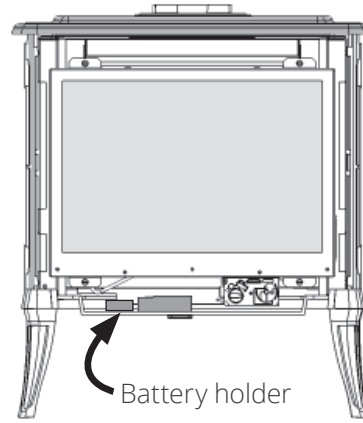

6. Use a heat-resistant tie to gather any extra cable between the receiver and the holder.

! Caution

DO NOT let the cable of the battery holder touch the burner plate above, it will melt during operation.

! Caution

Do not put batteries in the receiver as leaking acid could damage its circuit board.

Installation

Remote Control Pairing

Synchronize Receiver and Handset

The receiver and handset of the remote control system must be initially paired before the first use.

1. If not already done, place a new 9 V **alkaline** battery in the handset.
2. Identify the RESET button on the front of the receiver.
3. With a thin object, press and hold the receiver's reset button until you hear one short and one long beeps. Release the button after the second beep.
4. Within the next 20 seconds, press the small flame button () on the handset until you hear two short beeps confirming the pairing is set.
If you hear a long beep, the pairing has not been done or the wires are not connected correctly.

This is a one time setting only and is not required when changing the batteries in the remote handset. The remote control system is now ready to use.

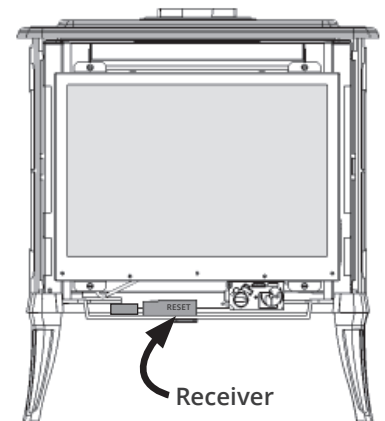
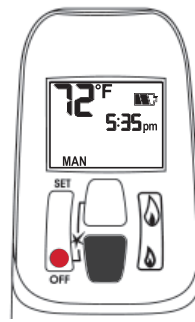

Installation

Operation Check & Burner Aeration

Check Operation

Turn the fireplace flame up and down using the remote control to confirm that the full range of inputs is achieved—see *Appendix B - Remote Control Operation* pages 41–44 for details.

Adjust Aeration (if needed)

Light the fire and allow the unit to warm up for 10–15 minutes to evaluate the flame picture. Burners are equipped with an adjustable shutter to control primary aeration. See figures below. The shutter is factory-set to an aeration gap which will give optimum performance for the vast majority of installations.

Air Shutter

The air shutter adjustment lever is located under the firebox. Move it left or right to adjust the air shutter.

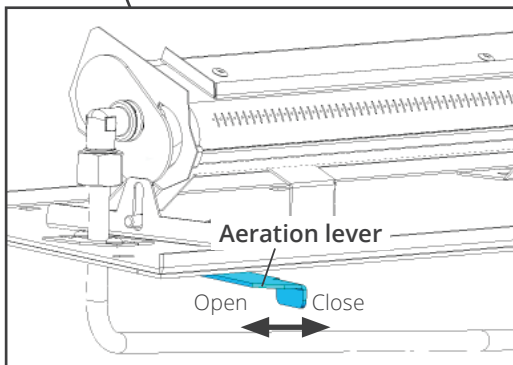
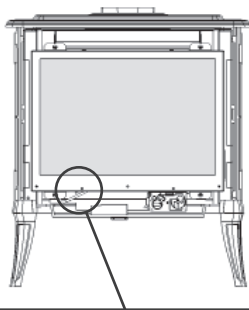

In some installations, depending of the fuel bed used, the altitude and other considerations, the flame picture may be improved by adjusting the aeration. The need for adjustment should be determined only by operating the appliance with the fuel bed and window installed and evaluating the flame picture after a 15-minute warm-up.

Increasing aeration (open) will cause the flames to appear more transparent and blue showing more ceramic effects glow.

Decreasing aeration (close) will cause flames to appear more yellow or orange showing less ceramic effects glow.

Too little aeration may result in black carbon forming on logs or roof panel and dropping into the firebox. May also result in carbon or soot stains on the vent termination and exterior wall around the termination! The Manufacturer is not responsible for for any damage caused by an air shutter setting with too little aeration.

Installation

Barrier Screen & Accessories

Front and Barrier Screen

Install the front chosen by the customer for the fireplace. Install as well the barrier screen which is provided with the front.

Show the customer how to access the controls when the front is installed and how to remove it.

Follow the instructions provided with the front and leave those instructions behind for the customer's further reference.

Handset Wall Holder

The remote control kit for this fireplace comes complete with a wall-mounted holder. This holder is not required in all installations but is provided as an optional feature for those customers who wish to mount the remote handset to the wall.

To install the holder to the wall, find a convenient location and use the hardware provided with the kit. See the diagram below for required hardware and configurations. Note that the holder can be installed at the base of a light switch plate.

IMPORTANT. The location of the remote control handset is important to insure proper temperature regulation. To obtain a constant temperature, we recommend that the handset should be between 3 and 15 feet away from the appliance but not directly above it. We also advise that the handset should be located away from any other heat source and not in direct sunlight as this may affect the temperature sensor located in the remote handset.

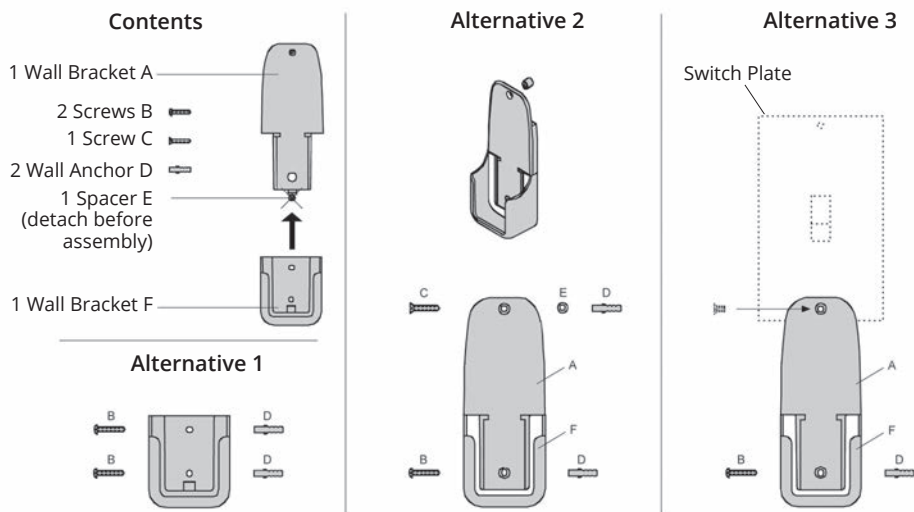

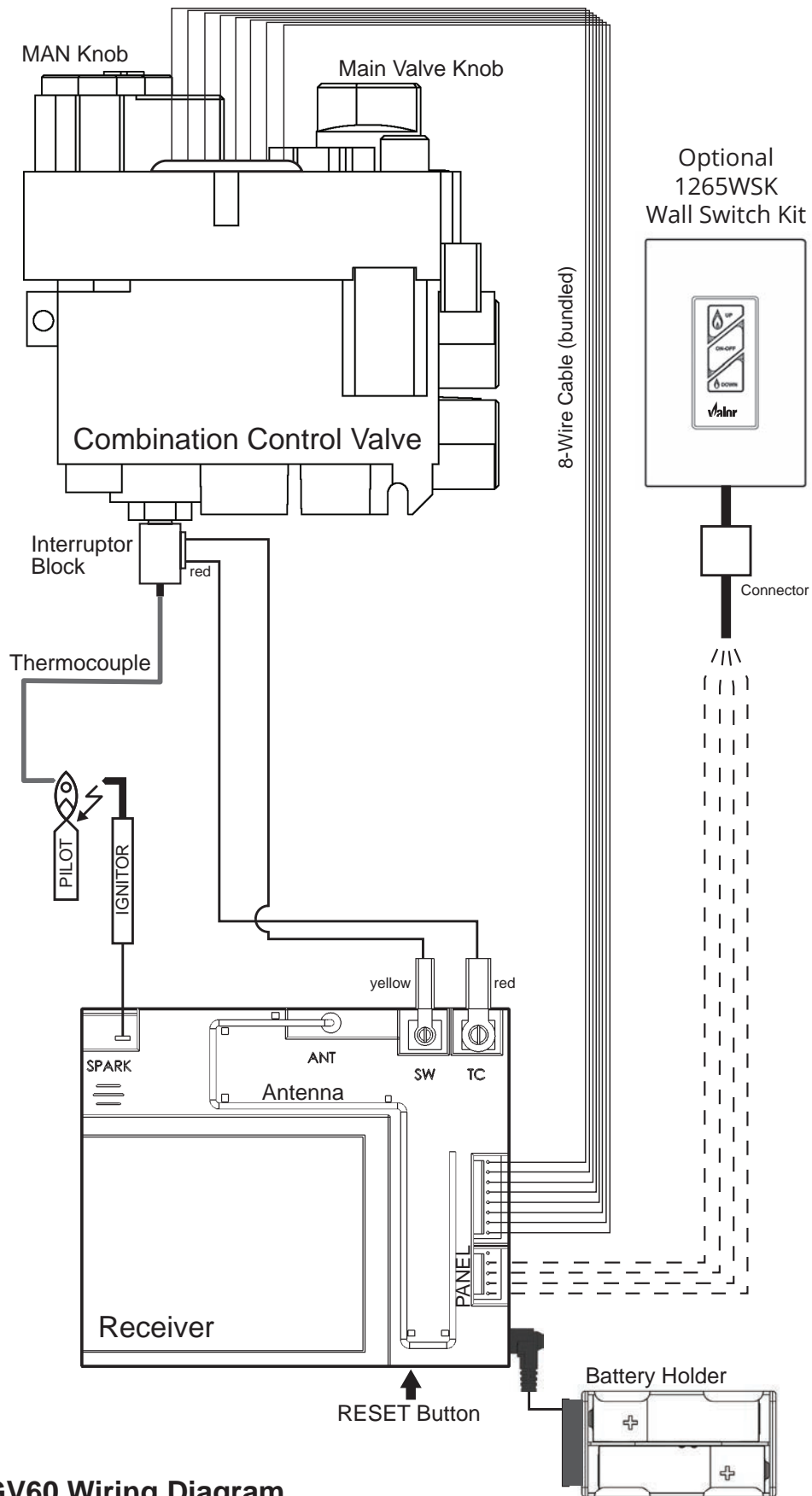

Wiring Diagram



GV60 Wiring Diagram

Approved Venting Components

Approved Direct Vent Suppliers for Valor Madrona MF28								
  Venting Parts Description		Venting Parts Code / availability by Manufacturer						
		DURA-VENT	SELKIRK	ICC EXCEL DIRECT	AMERIVENT	MILES INDUSTRIES	BDM	
Termination Caps	Horizontal	Standard Co-axial	46DVA-HC	4DT-HC	TM-4HT	4DHC round	658DVK2	DVR6-HCP
		Deluxe Co-axial	—	—	TM-4RHT	4DHCS square	—	DVR6-HC
		High Wind Co-axial	—	—	—	—	—	—
	Vertical	Standard Co-axial	46DVA-VC	4DT-VT	—	4DVC 4DH-1313	—	DVR6-VCH DVR6-VCSB
		High Wind Co-axial	46DVA-VCH	—	TM-4SVT	—	—	—
		Extended Co-axial	46DVA-VCE	—	—	—	—	—
		Snorkel, 36" Rise	46DVA-SNK36	4DT-ST36	TM-4ST36	4D36S	—	DVR6-SNK36
Vent Adapters / Couplers	Co-axial-to-Co-axial Flex Adapter	—	—	—	—	590CFA (5" x 3")	—	
Aluminum Flexible Liner	3" & 5" diameter	—	—	—	—	590FVK2 (5" x 3" kit)	—	
Adjustable Pipe Length and Pipe Extensions 4" x 6-5/8"	Galvanized or Black	46DVA-08A 46DVA-08AB (3" to 7")	—	—	4D7A or 4D7AB (3" to 5")	—	DVR6-08A DVR6-08AB	
	Galvanized or Black	46DVA-16A 46DVA-16AB (3" to 14-1/2")	—	TC-4DLS1 TC-4DLS1B	4D12A or 4D12AB (3" to 10")	—	DVR6-16A DVR6-16AB	
	Galvanized or Black	46DVA-17TA 46DVA-17TAB (11" to 17")	—	TC-4DLS2 TC-4DLS2B (1-7/8" – 21")	4D16A or 4D16AB (3" to 14")	—	—	
	Galvanized or Black	46DVA-24TA 46DVA-24TAB (17" to 24")	—	TC-4DLA30 TC-DLA30B (16.5" – 29")	4D26A or 4D26AB (3" to 24")	—	—	
	Co-axial Flex	46DVA-36FF 46DVA-60FF 46DVA-120FF	—	—	—	—	—	
DV Elbows	30°	Galvanized	46DVA-E30	—	—	—	—	
	45°	Galvanized	46DVA-E45 (swivel)	4DT-EL45	TE-4DE45	4D45L	—	DVR6-E45
		Black	46DVA-E45B (swivel)	4DT-EL45(B)	TE-4DE45B	4D45LB	—	DVR6-E45B
	60°	Galvanized	46DVA-E60	—	—	—	—	
	90°	Galvanized	46DVA-E90 (swivel)	4DT-EL90	TE-4DE90	4D90L	—	DVR6-E90
		Black	46DAV-E90B (swivel)	4DT-EL90(B)	TE-4DE90B	4D90LB	—	DVR6-E90B

Approved Venting Components

Venting Parts Description			Venting Parts Code / availability by Manufacturer						
			DURA-VENT	SELKIRK	ICC EXCEL DIRECT	AMERIVENT	MILES INDUSTRIES	BDM	
Pipes 4" x 6-5/8" (ID x OD)	6" long	Galvanized	46DVA-06	4DT-06	TC-4DL6	—	—	DVR6-06	
		Black	46DVA-06B	4DT-06(B)	TC-4DL6B			DVR6-06B	
	7" long	Galvanized	—	—	—	4D7	—	—	
		Black				4D7B			
	9" long	Galvanized	46DVA-09	4DT-09	TC-4DL9	—	—	DVR6-09	
		Black	46DVA-09B	4DT-09(B)	TC-4DL9B			DVR6-09B	
	12" long	Galvanized	46DVA-12	4DT-12	TC-4DL1	4D12	—	DVR6-12	
		Black	46DVA-12B	4DT-12(B)	TC-4DL1B	4D12B		DVR6-12B	
	18" long	Galvanized	46DVA-18	4DT-18	—	—	—	DVR6-18	
		Black	46DVA-18B	4DT-18(B)				DVR6-18B	
	24" long	Galvanized	46DVA-24	4DT-24	TC-4DL2	4D2	—	DVR6-24	
		Black	46DVA-24B	4DT-24(B)	TC-4DL2B	4D2B		DVR6-24B	
	36" long	Galvanized	46DVA-36	4DT-36	TC-4DL3	4D3	—	DVR6-36	
		Black	46DVA-36B	4DT-36(B)	TC-4DL3B	4D3B		DVR6-36B	
	48" long	Galvanized	46DVA-48	4DT-48	TC-4DL4	4D4	—	DVR6-48	
		Black	46DVA-48B	4DT-48(B)	TC-4DL4B	4D4B		DVR6-48B	
	Flashings	Roof Flashing 0/12-6/12		46DVA-F6	4DT-AF6	TF-4FA	4DF (0/12-5/12)	—	DVR6-AF012
		Roof Flashing 7/12-12/12		46DVA-F12	4DT-AF12	TF-4FB	4DF12 (6/12-12/12)	—	DVR6-AF712
Flat Roof Flashing		46DVA-FF	—	TF-4F	—	559FSK	DVR6-TCF		
Masonry Flashing		—	—	TF-4MF	—	—	—		
New Siding Flashing		—	—	—	—	658NSFK	—		
Various Venting System Parts	Wall Thimble		46DVA-WT	4DT-WT1	TM-4WT	4DWT	—	DVR6-WTU	
	Storm Collar		46DVA-SC	4DT-SC	TM-SC	4DSC	—	DVT68-SC	
	Decorative Plate		46DVA-DC	—	TM-4TR TM-4TP	4DFPB	—	DVR6-DC	
	Ceiling Support	Cathedral	46DVA-CS	4DT-CCS	TM-4SS	4DRSB	—	DVR6-CS	
		Regular	—	4DT-CS	—	—	—	—	
	Ceiling Firestop		46DVA-FS	4DT-FS	TM-4RDS	4DFSP	—	DVR6-CFS	
					TM-CS				
	Attic Radiation Shield / Firestop		46DVA-IS	ADT-41S	TM-4AS	4DAIS12 (12")	—	DVR6-AIS	
						4DAIS36 (36")			
	Wall Strap		46DVA-WS	4DTWSB	TM-WS	4DWS	—	DVR6-WS	
	Vinyl Siding Standoff		46DVA-VSS	4DT-VSS (before siding) 4DT-VSSB (after siding)	TM-VSS	4DHVS	—	DVR6-VSS	
Elbow Strap / Offset Support		46DVA-ES	4DT-OS	TM-OS	—	—	DVR6-ES		
Terminal Guard		46DVA-WG	—	TM-HTS	—	845TG	DVR6-SHRD		
				TM-RHTS		658TG			

- Notes:**
1. Follow instructions supplied with each manufacturer's components.
 2. Unless otherwise specified, all the parts and assemblies from the above table are to be used with 4" x 6-5/8" pipes.
 3. Do not mix components from different vent manufacturers, except those from Miles Industries which are approved to use with other manufacturer's.

Commonwealth of Massachusetts

State of Massachusetts Carbon Monoxide Detector/Vent Terminal Signage Requirements

For all side wall horizontally vented gas fueled equipment installed in every dwelling, building or structure used in whole or in part for residential purposes, including those owned or operated by the Commonwealth and where the side wall exhaust vent termination is less than seven (7) feet above finished grade in the area of the venting, including but not limited to decks and porches, the following requirements shall be satisfied:

1. INSTALLATION OF CARBON MONOXIDE DETECTORS.

At the time of installation of the side wall horizontal vented gas fueled equipment, the installing plumber or gas fitter shall observe that a hard wired carbon monoxide detector with an alarm and battery back-up is installed on the floor level where the gas equipment is to be installed. In addition, the installing plumber or gas fitter shall observe that a battery operated or hard wired carbon monoxide detector with an alarm is installed on each additional level of the dwelling, building or structure served by the side wall horizontal vented gas fueled equipment. It shall be the responsibility of the property owner to secure the services of qualified licensed professionals for the installation of hard wired carbon monoxide detectors.

a. In the event that the side wall horizontally vented gas fueled equipment is installed in a crawl space or an attic, the hard wired carbon monoxide detector with alarm and battery back-up may be installed on the next adjacent floor level.

b. In the event that the requirements of this subdivision can not be met at the time of completion of installation, the owner shall have a period of thirty (30) days to comply with the above requirements; provided, however, that during said thirty (30) day period, a battery operated carbon monoxide detector with an alarm shall be installed.

2. APPROVED CARBON MONOXIDE DETECTORS. Each carbon monoxide detector as required in accordance with the above provisions shall comply with NFPA 720 and be ANSI/UL 2034 listed and IAS certified.

3. SIGNAGE. A metal or plastic identification plate shall be permanently mounted to the exterior of the building at a minimum height of eight (8) feet above grade directly in line with the exhaust vent terminal for the horizontally vented gas fueled heating appliance or equipment. The sign shall read, in print size no less than one-half (1/2) inch in size, "GAS VENT DIRECTLY BELOW. KEEP CLEAR OF ALL OBSTRUCTIONS".

4. INSPECTION. The state or local gas inspector of the side wall horizontally vented gas fueled equipment shall not approve the installation unless, upon inspection, the inspector observes carbon monoxide detectors and signage installed in accordance with the provisions of 248 CMR 5.08(2)(a)1 through 4.

(b) EXEMPTIONS: The following equipment is exempt from 248 CMR 5.08(2)(a)1 through 4:

1. The equipment listed in Chapter 10 entitled "Equipment Not Required To Be Vented" in the most current edition of NFPA 54 as adopted by the Board; and

2. Product Approved side wall horizontally vented gas fueled equipment installed in a room or structure separate from the dwelling, building or structure used in whole or in part for residential purposes.

(c) MANUFACTURER REQUIREMENTS - GAS EQUIPMENT VENTING SYSTEM PROVIDED. When the manufacturer of Product Approved side wall horizontally vented gas equipment provides a venting system design or venting system components with the equipment, the instructions provided by the manufacturer for installation of the equipment and the venting system shall include:

1. Detailed instructions for the installation of the venting system design or the venting system components; and

2. A complete parts list for the venting system design or venting system.

(d) MANUFACTURER REQUIREMENTS - GAS EQUIPMENT VENTING SYSTEM NOT PROVIDED.

When the manufacturer of a Product Approved side wall horizontally vented gas fueled equipment does not provide the parts for venting the flue gases, but identifies "special venting systems", the following requirements shall be satisfied by the manufacturer:

1. The referenced "special venting system" instructions shall be included with the appliance or equipment installation instructions; and

2. The "special venting systems" shall be Product Approved by the Board, and the instructions for that system shall include a parts list and detailed installation instructions.

(e) A copy of all installation instructions for all Product Approved side wall horizontally vented gas fueled equipment, all venting instructions, all parts lists for venting instructions, and/or all venting design instructions shall remain with the appliance or equipment at the completion of the installation.

Appendix A – Lighting Instructions Plate

FOR YOUR SAFETY, READ BEFORE LIGHTING

WARNING: If you do not follow these instructions exactly a fire or explosion may result causing property damage, personal injury or loss of life.

- A. This appliance has a pilot which must be lighted by hand or by remote control. Follow these instructions exactly. To save gas, turn the pilot off when not using the appliance for a prolonged period of time.
- B. **BEFORE LIGHTING**, smell all around the appliance area for gas. Be sure to smell next to the floor because some gas are heavier than air and will settle on the floor.

WHAT TO DO IF YOU SMELL GAS

- Do not try to light any appliance.
 - Do not touch any electric switch; do not use any phone in your building.
 - Immediately call your gas supplier from a neighbor's phone. Follow the gas supplier's instructions.
 - If you cannot reach your gas supplier, call the fire department.
- C. Use only your hand to push in or turn the control knobs. Never use tools. If the knobs will not push in or turn by hand, don't try to repair them; call a qualified service technician. Force or attempted repair may result in a fire or explosion.
- D. Do not use this appliance if any part has been under water. Immediately call a qualified service technician to inspect the appliance and to replace any part of the control system and any gas control, which has been under water.

LIGHTING INSTRUCTIONS

1. **STOP!** Read the safety information above
2. **TO CLEAR ANY GAS**, turn main valve off by pressing OFF (red dot) button on remote handset (1). Wait five (5) minutes to clear out any gas, then smell for gas, including near the floor. If you smell gas, **STOP!** Follow "B" in the safety information above on this label. If you don't smell gas, go to the next step.
3. **AUTOMATIC IGNITION:** MAN-knob (2) in ON position. Ensure Flame Adjustment knob (3) is set to lowest setting (☺) (Fig. 1). Locate the pilot (Fig. 3) inside firebox. On the remote control handset, press the OFF button (red dot) and large flame button (🔥) simultaneously; a short acoustic signal confirms the start has begun. Further short acoustic signals indicate the ignition process is in progress. When the pilot is lit, the Flame Adjustment knob (3) will automatically rotate to the highest setting. Press the small flame button (🔥) on the remote.
4. **MANUAL IGNITION:** MAN-knob (2) in MAN position (Fig. 2). With the window off, locate the pilot (Fig. 3) inside firebox. Set Flame Adjustment knob (3) to the lowest setting (☺). Push down the metallic core (4) with a pin or similar instrument; this will establish the pilot gas flow. Light gas at the pilot (5) with a match. Continue holding down metal core (4) for about 10 seconds; after release, pilot should remain lit. If the pilot will not stay lit after several tries, turn the gas control knob (3) to OFF (☺) and call your local service technician or gas supplier. Reinstall the window and set the MAN-knob (2) to ON; turn Flame Adjustment knob (3) up (☺) or down (☹) manually or use the flame buttons (🔥) (🔥) on the remote control handset to adjust the flame height.

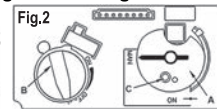
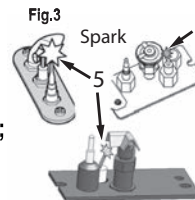
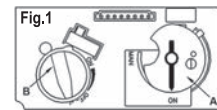
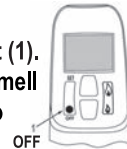

TO TURN OFF GAS TO APPLIANCE

1. **AUTOMATIC SHUT-OFF** (using the remote control handset):
 - Press and hold the small flame on the remote control handset to shut-off the main burner gas flow;
 - Press "OFF" button (red dot) on remote handset to shut-off the appliance, including pilot flame.

CAUTION: Due to high surface temperature, keep children, clothing and furniture away. Keep burner and control compartment clean.

See installation and operating instructions accompanying the appliance.

WARNING: Improper installation, adjustment, alteration, service or maintenance can cause injury or property damage. Refer to the owner's information manual provided with this appliance. For assistance or additional information consult a qualified installer, service agency or gas supplier.

THIS APPLIANCE MUST BE INSTALLED IN ACCORDANCE WITH LOCAL CODES, IF ANY. IF NONE, FOLLOW THE NATIONAL FUEL GAS CODE, ANSI Z 233.1, OR CANADIAN INSTALLATION CODES, CAN/CGA-B149.

DO NOT REMOVE FROM FIREPLACE

4000961-10

Appendix B – Remote Control Operation

Radio Frequency

315 MHz for USA and Canada.

This device complies with Part 15 of the FCC Rules and with Industry Canada license-exempt RSS standard(s). Operation is subject to the following two conditions:

- (1) this device may not cause harmful interference, and
- (2) this device must accept any interference received, including interference that may cause undesired operation.

NOTE: Before using the remote control system for the first time, the receiver and the handset must be synchronized. See *Remote Control Pairing* page in this manual.

33

IMPORTANT: BEFORE YOU BEGIN, please note that on this system, the settings of time, temperature and automatic ON/OFF **can only be programmed when the function display is flashing.** Be patient when programming as it can take a few seconds to set.

Note: In the TEMP or TIMER modes, the remote handset senses the room temperature and adjusts the flame accordingly.

To communicate, the handset should be within 15 feet (4.5 meters) of the fireplace.

Do not leave the handset on the mantel or hearth.

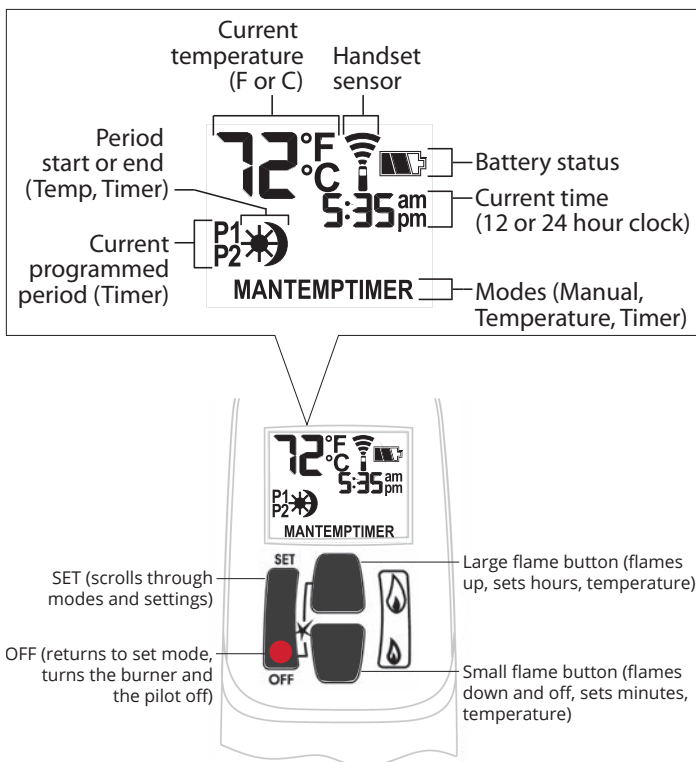

Turn Fireplace ON

Press ● + 🔥 buttons until you hear a short beep; release buttons.

Beeping continues until pilot is lit.

Burner lights to maximum flame height and handset goes automatically to manual (MAN) mode.

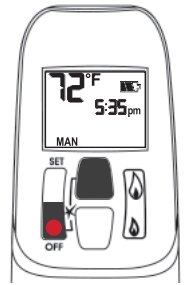

NOTES:

On the valve, MAN button must be at ON, in full counter-clockwise position ↺.

Turn Fireplace OFF

Press ● button.

When pilot is just turned off, wait 2 minutes to light it again.

Standby Mode (Pilot Flame)

Press and hold 🔥 to set fireplace to pilot.

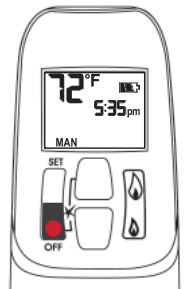

Adjust Flames Height

With pilot lit, press and hold buttons:

- 🔥 = increase flame height
- 🔥 = decrease flame height or set to pilot

For fine adjustment, tap buttons.

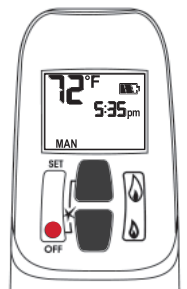

Express Low and High Fire

Double-click buttons:

- 🔥 = increase flame to maximum height "HI"
- 🔥 = decrease flame minimum height "LO"

NOTE: Flame goes to high fire first before going to designated low fire.

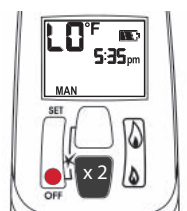
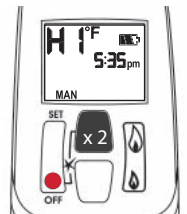

Appendix B – Remote Control Operation

Setting °C/24-hr or °F/12-hr clock

In MAN mode, press and hold ● + 🔥 buttons until temperature / clock display changes from

°F / 12-hour ↔ °C / 24-hour

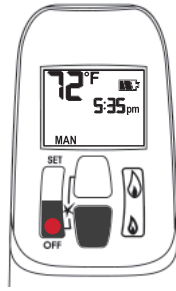

MAN Manual Mode

Manual flame height adjustment.



☀️ TEMP Daytime Temperature Mode

When pilot is lit, room temperature is measured and compared to set temperature. Flame height automatically adjusts to reach Daytime Set Temperature.



Setting Time

The time display will flash after either:

- installing the battery, or
- pressing 🔥 + 🔥

To set the time, press buttons:

🔥 = hour

🔥 = minutes

Press ● or wait to go back to MAN.

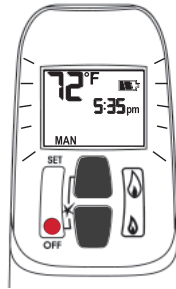

🌙 TEMP Night time Setback Temperature Mode

When pilot is lit, room temperature is measured and compared to set temperature. Flame height automatically adjusts to reach Night Time Setback Temperature.

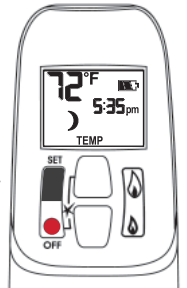

TIMER Timer Mode

When pilot is lit, two periods of time (P1 and P2) can be programmed to use Daytime and Night time temperatures at specific times.

Note: Display shows set temperature every 30 seconds.



Modes of Operation

Briefly pressing SET cycles through modes of operation.

MAN > ☀️ TEMP > 🌙 TEMP > TIMER > MAN

NOTE: Press 🔥 or 🔥 to reach MAN mode.

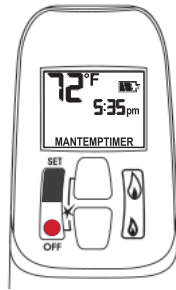

Set the different parameters when they are flashing.

Appendix B – Remote Control Operation

Setting high / low Temperatures

Setting “DAYTIME” high temperature.

Default Settings: TEMP 23 °C/74 °F

Press SET to scroll to TEMP

Hold SET button until TEMP flashes.

To set Daytime Temperature:

= increases temperature.

= decreases temperature.

Press or wait to complete setting.

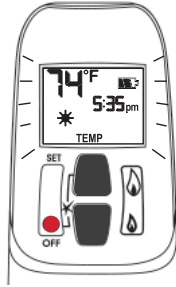

Setting “NIGHT TIME SETBACK” low temperature.

Default Settings: TEMP “--” (OFF)

Press SET to scroll to TEMP

Hold SET button until TEMP flashes.

To set Night Time Temperature:

= increases temperature.

= decreases temperature.

Press or wait to complete setting.

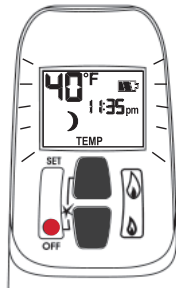

Setting Program Timers

You can program two periods of time between 12 am and 11:50 pm in each 24-hour cycle.

Programs P1 and P2 must be set in the following order during a 24-hour cycle: **P1** , **P1** , **P2** and **P2** .

= Day Time temperature (high) program period

= Night Time temperature (low) program period

Default Settings:

Program 1: **P1** 06:00 am **P1** 08:00 am

Program 2: **P2** 11:50 pm **P2** 11:50 pm

Press SET to scroll to .



If **P1** = **P1** or **P2** = **P2** , programming is cancelled.

To keep fireplace ON all night, set **P2** at 11:50 am and **P1** at 12:00 am.

If you want to program only one period, program **P1** and **P1** with desired times then **P2** and **P2** with the same time as **P1** .

Setting P1 time—high temperature.

Hold SET button until **P1** is displayed and time flashes.

To set time:

= hour

= minutes

Press or wait to complete setting.

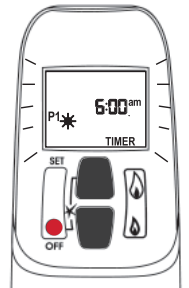

Setting P1 time—low temperature.

Hold SET button until **P1** is displayed and time flashes.

To set time:

= hour

= minutes

Press or wait to complete setting.

Appendix B – Remote Control Operation

Setting P2 high and low temperature times.

Repeat same steps as Setting P1.

When all settings are complete, press ● to save them.

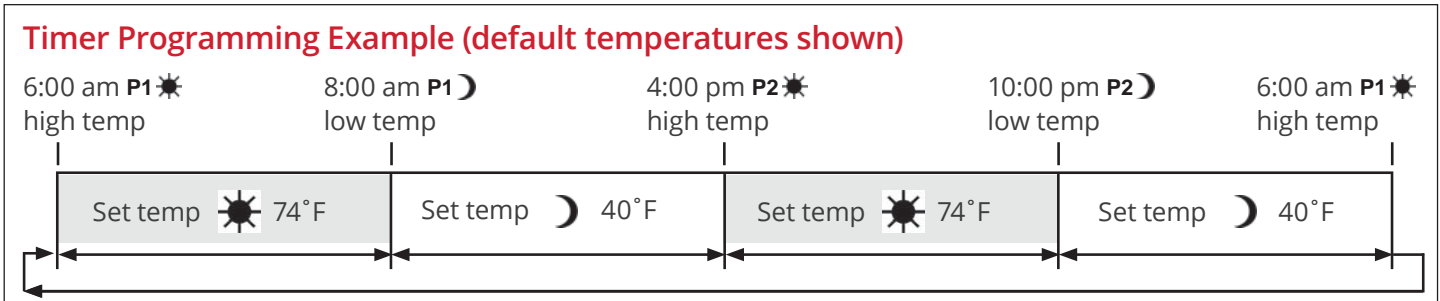

Automatic Turn Down

8-Hour no Motor Movement

The valve will turn to pilot flame if there is no motor movement for an 8-hour period.

Automatic Shut-Off

Low Batteries Receiver. With low battery power in the battery holder the system shuts off the fire completely. This does not apply when the power supply is interrupted.

On-Demand Pilot (7 Day Shut-Off). This green feature eliminates gas energy consumption during extended appliance inactivity. When the appliance is inactive for an extended period of time the system automatically extinguishes the pilot. This feature helps the consumer realize cost benefits by automatically eliminating energy consumption during non-heating months and limited use.

The programmed length of inactivity to activate the system is specified by the appliance manufacturer and cannot be altered in the field.

Low Battery Indication

! Caution

DO NOT USE a screwdriver or other metallic object to remove batteries from holder. This could cause a short-circuit.

Handset: The battery icon  will show when the battery needs to be replaced. Replace with one 9 V **alkaline** battery.

Battery holder: Frequent 'beeps' for 3 seconds when the valve motor turns indicate the batteries need to be replaced in battery holder. Replace with four 1.5 V **alkaline** batteries.

Handset / Receiver Match

The remote control handset and receiver are programmed to function together. In case of a replacement of the handset or the receiver, you will need to reset the receiver to allow them to function together. Contact your dealer for details.

Appendix C – Spare Parts

	Description	Part. no.
1	Restrictor 50 (2)	4000949
2	Restrictor 75 (2)	4000950
3	Dura-Vent Intake Collar	4000925
4	Intake Collar Gasket	4000942
5	Exhaust Collar Assembly	4000918
6	Exhaust Collar Gasket	4000938
7	Intake Plate	4000908
8	Intake Plate Gasket	4000941
9	Top Spar—not used with MFCS05	4000916
10	Heat Reduction Baffle	4000974
11	Air Baffle	4011527
12	Burner Cover	4011523
13	Window Assembly	4000919
14	Hot Glass Warning Plate	4003093
15	Burner Tray Assy (natural gas)	4011516
	Burner Tray Assy (propane gas)	4011872
16	Injector Elbow 82-750 (natural gas)	4000738
	Injector Elbow 92-300 (propane gas)	9730007
17	Steel flat washer 0.37 inch	4007461
18	Spring tension washer 10 mm double wave	4007460
19	Air shutter—natural gas	4011918
	Air shutter—propane gas	4012151
20	Anti-flashback shield	4007629
21	Burner	4007354
22	Burner mounts (2)	4008431
23	PSE Pilot assy 36"—natural gas	4008484
	PSE Pilot assy 36"—propane gas	4008485
24	Thermocouple assembly	4008490
25	Pilot injector PSE-730—natural gas	4008493
	Pilot injector PSE-727—propane gas	4008494
26	Pilot tube	4008486
27	Pilot gaskets (2)	4000715
28	Pilot stand	4007751
29	Burner module plate	4011518
30	Module gasket rear	4000642
31	Module gasket left side	4000643
32	Module gasket front	4000641
33	Module gasket right side	4000644
34	Link bracket	4011915
35	Pipe sealing plate	4011394
36	Aeration lever	4008698
37	Washers #10 x 0.562 plated (3)	4006692
38	Spring washers 3/16 x 9/16 (3)	4006691
39	#10-24 zinc finish steel reverse nut (3)	4007890

	Description	Part. no.
40	Valve mount	4000141
41	Gas supply tube assembly	4011554
42	GV60 gas valve—natural gas	4011893
	GV60 gas valve—propane gas	4011894
43	Thermocurrent Interruptor	4001037
44	Receiver 'PLUS' version	4001911
45	Receiver mounting bracket	4001164
46	Inlet Pipe	4008475
47	Pipe Clamp	4008498
48	Wiring harness	4001187
49	Cable Interruptor/Receiver, yellow	4002096
50	Cable Interruptor/Receiver, red	4001035
51	Auxiliary Battery Holder	4006553
52	Battery Holder Cable 1500 mm	4006552
53	Handset 'PLUS'	4001910
54	Handset Wall Holder	9000008
55	Fan Control Bracket	9000946
56	Traditional Log Set	MF28VLSK
	Traditional logs only	4009674
	Traditional Log #G41	4009587
	Traditional Log #G37	4009583
	Traditional Log #G38	4009584
	Traditional Log #G42	4009588
	Traditional Log #G40	4009585
	Traditional Log #G39	4009586
	Forge Embers, 2.5 cup bag	4008304
	Traditional Center Ember G49	4009597
57	Driftwood Kit	MF28VDWK
	Driftwood Rear #G51	4009599
	Driftwood Left #G53	4009601
	Driftwood Right #G52	4009600
	Driftwood Twig Center #G57	4009605
	Driftwood Log Mid #G58	4009615
	Driftwood Twig Right #G55	4009603
	Driftwood Ember Bed #G54	4009602
	Driftwood Front Ember Bed #G56	4003087
	Brown Beach Pebble	4003082
	Small Grey Beach Pebble	4003086
	Small Beige Beach Pebble	4003087
58	Birch Logs Kit	MF28VBLK
	Birch logs only	4009675
	Birch Log #G45	4009593
	Birch Log #G43	4009590
	Birch Log #G44	4009589
	Birch Log #G48	4009596

Appendix C – Spare Parts

	Description	Part. no.
	Birch Log #G46	4009594
	Birch Log #G47	4009595
	Forge Embers, 2.5 cup bag	4008304
	Birch Center Ember G50	4009598
59	GV60 Valve Repair Kit	4004544

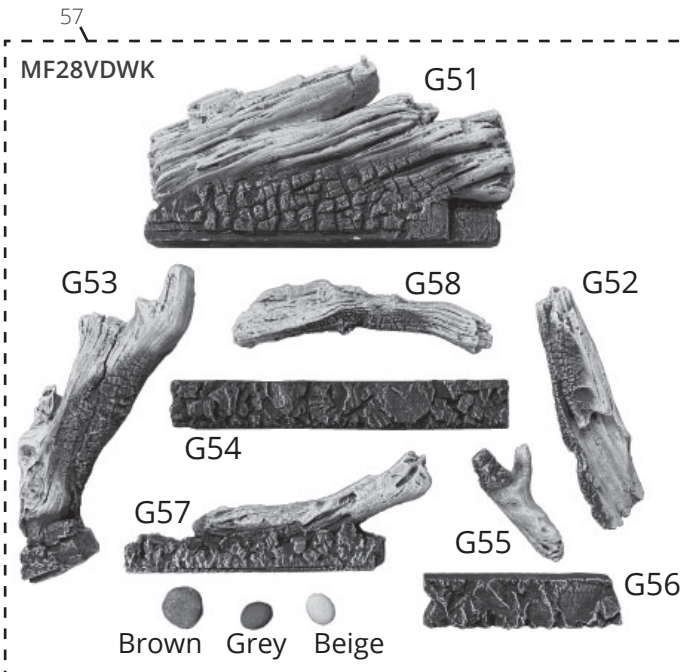
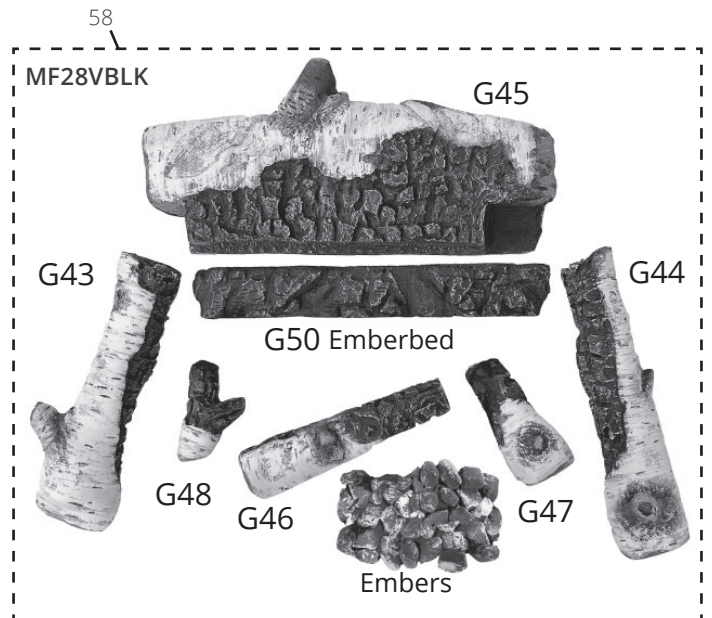
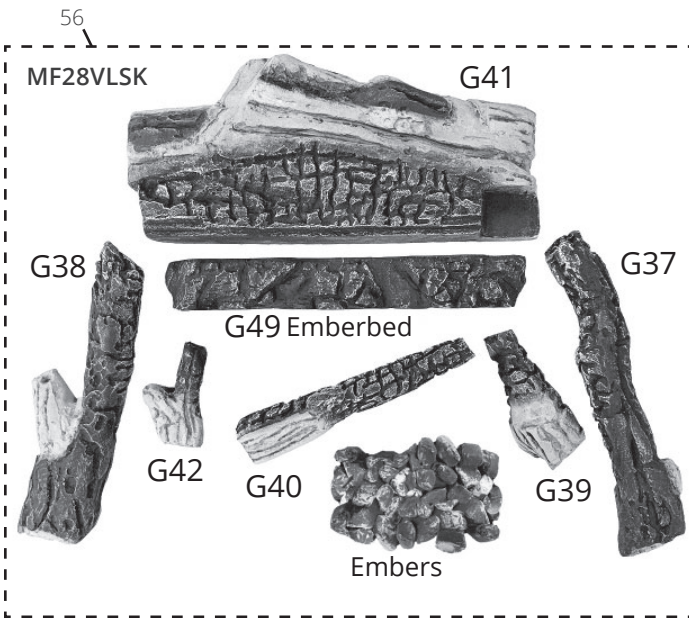

Appendix C – Spare Parts

